



# FY-27 Navy Reserve Line Community Brief Disclaimer

---

**This community brief has been generated by the community leaders, including detailers and community managers. It has been vetted by Navy Personnel Command and OJAG for statutory compliance and approved by SECNAV.**

**Community leaders have provided these slides to community members for career planning purposes; however, strict adherence to the career progressions depicted in the slides is not a prerequisite for promotion.**

**ONLY MATERIAL APPROVED BY THE SECRETARY OF THE NAVY WILL BE PRESENTED TO STATUTORY SELECTION BOARDS. THIS BRIEF HAS BEEN APPROVED BY SECNAV FOR USE BY THE FY-27 STATUTORY SELECTION BOARDS.**



# Aerospace Engineering Duty Officer

## Career Progression

### Career Path

O3 and below Milestone*	O4 Milestone*	O5 Milestone*	O6 Milestone*
FLEET: Squadron Aircrew	XO NAVAIR O5 Command or DH NAVAIR O6 Command Project Lead Deputy Mission/IPT Lead	CO NAVAIR O5 Command XO NAVAIR O6 Command Mission/IPT Lead Deputy Chief of Staff	NAVAIR Chief of Staff CO NAVAIR O6 Command Military/Mission Director
DCO: Acquisition/Engineering/Research Operational Experience			

AC Lateral-Transfer Window  
4 - 14 YCS

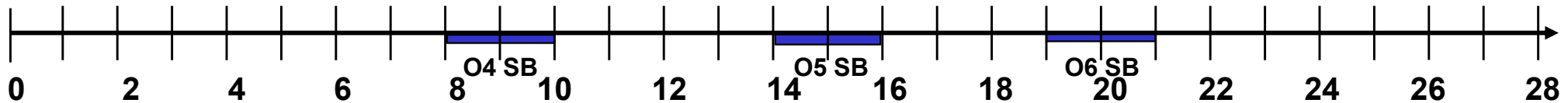

### Training / Certification

DAWIA Legacy Level I Engineering or Engineering & Technical Management (ETM) Foundational Certification

Master's Degree (Technical / Business)  
DAWIA Legacy Level II Engineering or  
ETM Practitioner Certification

\* Career Milestones arranged in descending order, most valued experience or position listed on top



# Aerospace Engineering Duty Officer

## *Community Values*

- **Sustained superior performance, leadership and expertise in demanding billets and assignments**
- **Evidence of a learning mindset, innovative problem solving and data-driven decision making**
- **Valued Reserve contributions to Navy mission via operational / mobilization assignments and Canvasser Recruiter duty during FY23 and beyond**
- **Valued achievements at all paygrades\***
  - Consistent demonstration of leadership and technical expertise in increasingly challenging acquisition billets
  - Mobilization or active duty for operational support (ADOS), preferably in support of the Naval Aviation Enterprise
  - Master's degree (technical or business)
  - Community Engagement (AEDO Council of Captains Secretary, DCO Coordinator, ADCOS)
- **Valued achievements prior to LIEUTENANT COMMANDER\***
  - Department Head O5 Command or Asst. Department Head O6 Command
  - Project Lead
  - Operational squadron junior officer tours (for prior Naval Aviator/Naval Flight Officers)
- **Valued achievements prior to COMMANDER\***
  - XO NAVAIR O5 Command or Department Head O6 Command
  - Deputy mission or IPT lead
  - DAWIA Legacy Level I Certification\*\* – Engineering preferred or Engineering & Technical Management (ETM) Foundational
- **Valued achievements prior to CAPTAIN\***
  - CO NAVAIR O5 Command
  - XO NAVAIR O6 Command
  - Mission or IPT Lead, or Deputy Chief of Staff
  - DAWIA Legacy Level II Certification – Engineering preferred or ETM Practitioner / Additional DAWIA Legacy Level II

\*Arranged in descending order, most valued experience or position listed on top

\*\* Completion of all course work in lieu of DAWIA certification is acceptable



# Aerospace Maintenance Duty Officer

## Career Progression

AMO: Assistant Maintenance Officer DCOS: Deputy Chief of Staff FRC: Fleet Readiness Center ADCoS: Asst. Deputy Chief of Staff	IPT: Integrated Program Team LCL: Logistics Life Cycle MMCO: Maintenance Material Control Officer PQM: Production, Quality, and Manufacturing PM: Program Management
--	--

### Career Path

O3 and below Milestone*	O4 Milestone*	O5 Milestone*	O6 Milestone*
<b>SHORE/SEA</b> O-Level AMO / MMCO I-Level/FRC DIVO	<b>XO NAVAIR O5 Command or            DH NAVAIR O6 Command</b> Project Lead Deputy Mission/IPT Lead	<b>CO NAVAIR O5 Command            XO NAVAIR O6 Command</b> Mission/IPT Lead Deputy Chief of Staff	<b>NAVAIR Chief of Staff            Commanding Officer            Military/Mission Director</b>
<b>ON RAMP - JO Sea &amp; Shore Tours</b>			

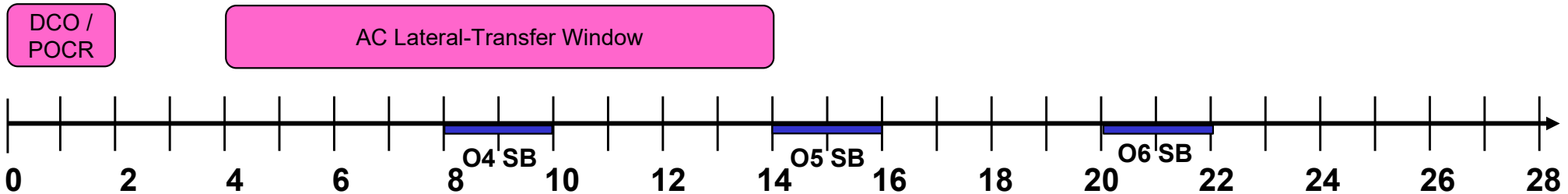

### Training / Certification

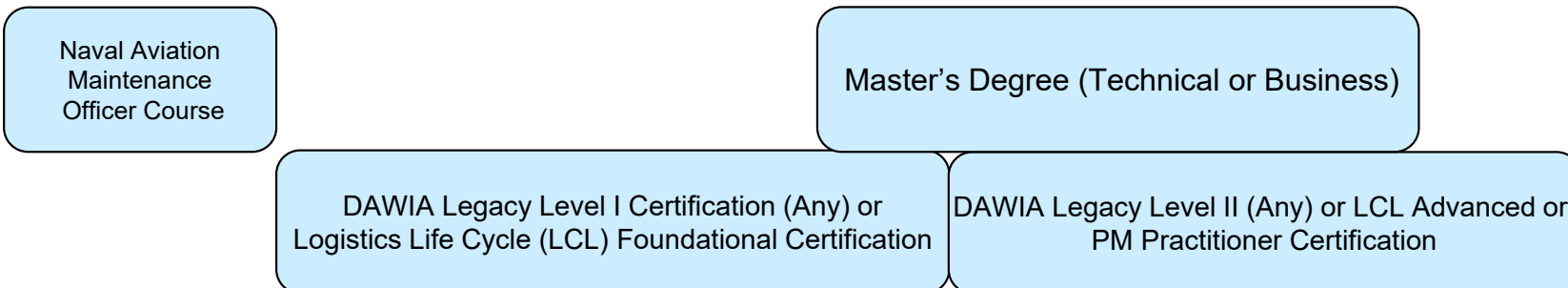

\* Career Milestones arranged in descending order, most valued experience or position listed on top



# Aerospace Maintenance Duty Officer

## *Community Values*

- **Sustained superior performance, leadership and expertise in demanding billets and assignments**
- **Evidence of a learning mindset, innovative problem solving and data-driven decision making**
- **Valued Reserve contributions to Navy mission via operational / mobilization assignments and Canvasser Recruiter duty during FY23 and beyond**
- **Valued achievements at all paygrades\***
  - Consistent demonstration of leadership and technical expertise in increasingly challenging acquisition/maintenance billets
  - Mobilization or active duty for operational support (ADOS), preferably in support of the Naval Aviation Enterprise
  - Experience in Organizational (O-level) or Fleet Readiness Center (FRC) Intermediate (I-level) or Depot (D-Level) maintenance
  - Community Engagement (AMDO ESC/Council of Captains Secretary, DCO Coordinator, ADCOS)
  - Master's degree (technical or business)
- **Valued achievements prior to LIEUTENANT COMMANDER\***
  - Squadron AMO / DET MO / MCO / MMCO, FRC DIVO
  - Department Head O5 Command or Asst. Department Head O6 Command
  - Project Lead
- **Valued achievements prior to COMMANDER\***
  - XO NAVAIR O5 Command or Department Head O6 Command
  - Detachment Maintenance Officer or Assistant Maintenance Officer (AMO)
  - Deputy mission or IPT lead
  - DAWIA Legacy Level I Certification:\*\* Production, Quality, Manufacturing (PQM), Life Cycle Logistics (LCL), or Program Management (PM) or LCL Foundational Certification
- **Valued achievements prior to CAPTAIN\***
  - CO NAVAIR O5 Command
  - XO NAVAIR O6 Command
  - Mission or IPT lead, or DCOS positions
  - Experience in NAVAIR Logistics, Program Management, or FRC billets
  - DAWIA Legacy Level II Certification – LCL Advanced / or PM Practitioner

\*Arranged in descending order, most valued experience or position listed on top

\*\* Completion of all course work in lieu of DAWIA certification is acceptable



# Aerospace Maintenance Duty Officer (TAR)

## Career Progression

### Career Path

APML: Assistant Program Manager Logistics AMO: Assistant Maintenance Officer AOIC: Assistant Officer In Charge COR: Contracting Officer Representative DPM: Deputy Program Manager FRC: Fleet Readiness Center	MMCO: Maintenance Material Control Officer MO: Maintenance Officer NRC: Naval Reserve Center PCO: Production Control Officer RPD: Reserve Program Director TPOC: Technical Point of Contact
---	--

Squadron AMO / MMCO or Squadron COR / TPOC	FRC AOIC / MMCO / PCO, AMMT Lead or WING AMO / RO	FRC MO / OIC / XO or WING MO or NRC CO	FRC CO NAVAIR RPD/CO CNAFR MO PMA-207 DPM
FRC MMCO / DIVO	Staff / Acquisition	Staff / Acquisition	

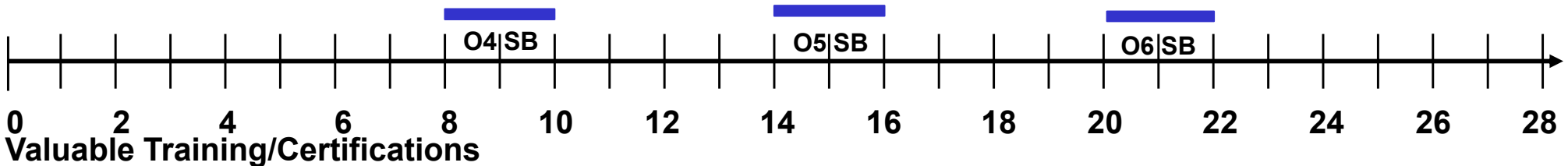
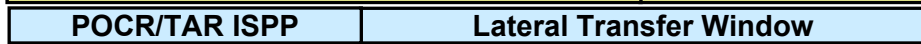

TAR AMDO career paths are tailored based on accession timing and variety of experience.

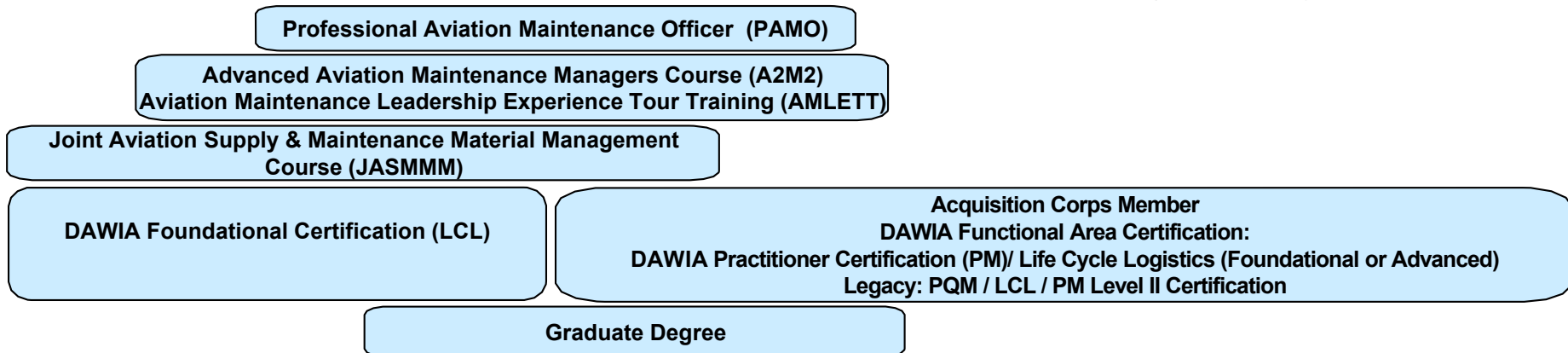



# Aerospace Maintenance Duty Officer (TAR)

## *Community Values*

- **Sustained superior performance, leadership and expertise in demanding billets and assignments**
- **Evidence of a learning mindset, innovative problem solving and data-driven decision making**
- **Career progression produces senior AMDOs with steadfast character, a strong maintenance background, demonstrated business acumen and that are prepared to lead large complex acquisition and sustainment organizations for Reserve Naval Aviation.**
  - Support the Naval Reserve mission and the Naval Aviation Enterprise
  - Values are listed in decreasing precedence of importance from top to bottom
- **Valued achievements prior to LIEUTENANT COMMANDER**
  - Superior performance in both Squadron and FRC positions (Organizational, Intermediate, or Depot Level)
  - Professional Aviation Maintenance Officer (PAMO) desired
  - DAWIA Foundational Certification (LCL) desired
  - Master's degree desired
  - Joint Aviation Supply & Maintenance Material Management Course (JASMMM) desired
  - Advanced Aviation Maintenance Manager's Course (A2M2) desired
- **Valued achievements prior to COMMANDER**
  - Superior performance in jobs with increasing complexity, scope, responsibility
  - Professional Aviation Maintenance Officer (PAMO) qualification required
  - Acquisition Professional Membership required
  - Master's degree required
  - DAWIA Practitioner Certification (PM) or Foundational Life Cycle Logistics (LCL) or Legacy Certification (PQM/LCL/PM Level II)
- **Valued achievements prior to CAPTAIN**
  - Superior performance and proven ability in leading and directing people and organizations in tough, highly visible, and challenging environments
  - DAWIA Advanced Certification (LCL) or Program Management (PM) Practitioner
  - Professional Aviation Maintenance Officer (PAMO) qualification required



# Aviation Officer Career Progression

## Career Path

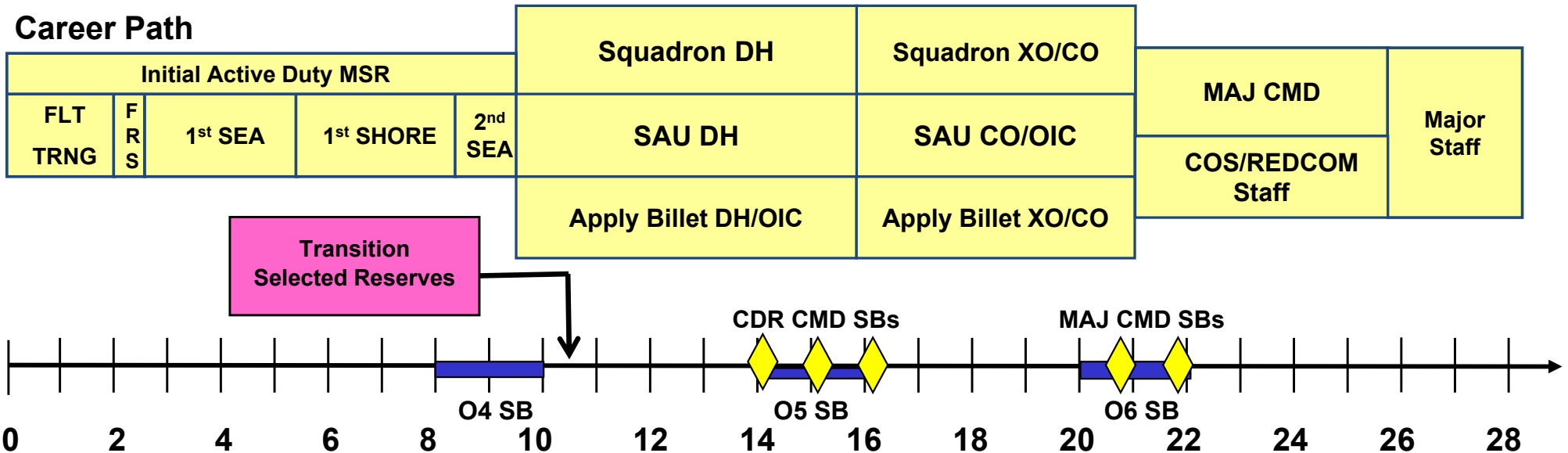

## Typical Billets

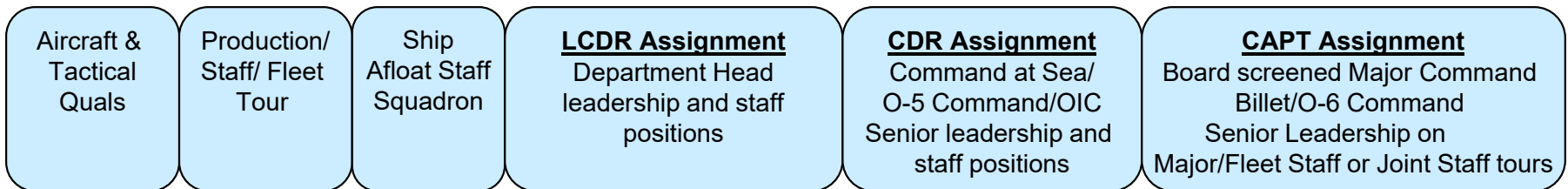



# Aviation Officer

## Community Values

- **Sustained superior performance, leadership and expertise in demanding billets and assignments**
- **Evidence of a learning mindset, innovative problem solving and data-driven decision making**
- **Valued Reserve contributions to Navy mission via operational / mobilization assignments and Canvasser Recruiter duty during FY23 and beyond**
- **AVN officers have a long training pipeline, resulting in NOB FITREPS for first 3-4 years**
  - MSR retains Navy pilots through approx. 11 YCS and NFOs approx. 9 YCS
- **Valued achievements prior to LIEUTENANT COMMANDER**
  - Superior performance during Fleet Squadron/Production tour and attainment of initial warfare qualifications
  - Superior performance in subsequent shore tour
    - Operational/Production tours valued (Weapons School, FRS, VFC, VT/HT, Test Pilot)
- **Valued achievements prior to COMMANDER**
  - Superior performance as Squadron DH (Operations/Maintenance and EP DH reflected in FITREP)
  - Superior performance as a SAU DH (XO/Operations/STUCON) or in Apply leadership positions (XO, N3/N5, N1)
  - Competitive EP Highwater FITREP
  - OLW experience or training (tour / named exercise / education / course)
- **Valued achievements prior to CAPTAIN**
  - Operational Squadron Command tour (VR, VP, HSM, HSC, VP, VUP, VAQ, VFC, VT, HT)
  - Top performer in SAU Command or Apply / board-selected CO/OIC billet
  - Sustained superior performance in Apply / board-selected major staff and leadership positions
  - Fleet MOC experience / OLW
- **Other Considerations**
  - Warfighting focused qualifications valued (MISR/ Air Logistics SME/VARMITT/WTI Qualification)
  - Professional or personal development that contributes to warfighting readiness (JPME I/II, JQO, Master's Degree, OLW)
    - Other schools/courses/qualifications/designations/exercises



# Aviation Officer (TAR)

## Career Progression

### Career Path

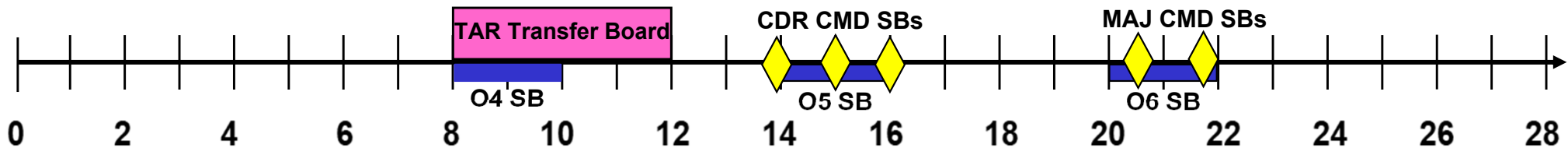
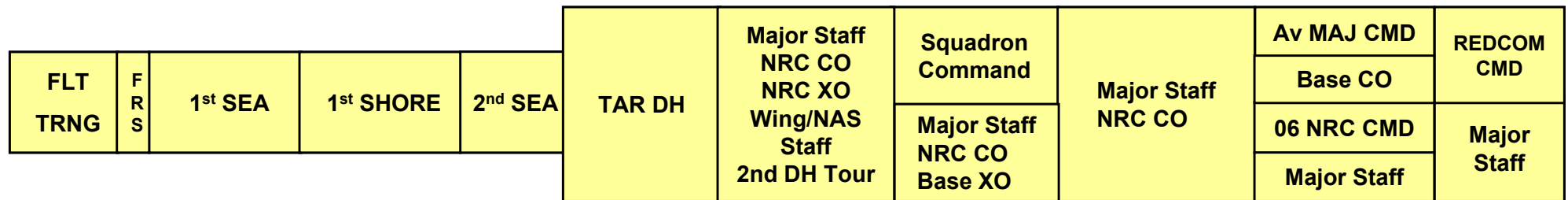

### Typical Billets

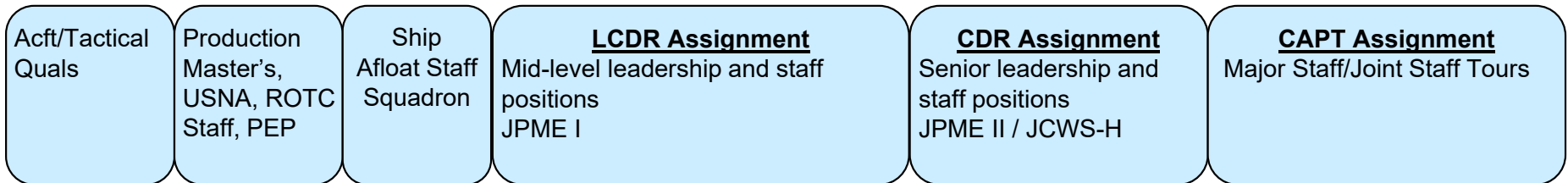

### RESERVE MANAGEMENT CAREER PATH:

NRC CO – 24-36 Month Tours  
Major Staff (OCNR/CNRF/CNAFR/REDCOM/RPD)



# Aviation Officer (TAR)

## Community Values

- **Sustained superior performance, leadership and expertise in demanding billets and assignments**
- **Evidence of a learning mindset, innovative problem solving and data-driven decision making**
- **AVN officers have a long training pipeline, resulting in NOB FITREPS first 3-4 years**
  - Min service requirement retains most aviators through 11 years
- **Valued achievements prior to LIEUTENANT COMMANDER**
  - Fleet Squadron tour
  - Superior performance in subsequent shore tour
    - Production tours most valued (Weapons School, FRS, VFC, VT, HT, Test Pilot)
- **Valued achievements prior to COMMANDER**
  - Squadron major DH (Operations/maintenance or EP DH reflected in FITREP)
  - Major staff tour or nominative community staff assignment (OPNAV, PERS, CNAFR, CNAP, CNAL, CNRFC, Fleet Staff or Joint Tours)
  - Top performer in O4 NRC command tour
  - Established sustained superior performance, EP Highwater FITREP and increasing responsibility
  - Master's degree or JPME I awarded (Not required until assuming O5 CMD)
- **Valued achievements prior to CAPTAIN**
  - Successful Squadron command tour (VR, VP, HSM, HSC, VUP, VAQ, VFC, VT, HT)
  - Successful RTAG/NTAG command tour
  - Top performer in O5 NRC command tour
  - Sustained superior performance in major staff and Reserve management leadership positions
- **Reserve management career path**
  - Officers serving in Reserve management/leadership positions that are directly supporting the mission of the Reserve Component (e.g., OCNR, CNRFC, REDCOM, BUPERS). Note: All CNAFR Commands perform extensive Reserve Management functions in addition to operational missions
  - Subspecialty utilization as defined in the precept



# Cryptologic Warfare Officer

## Career Progression

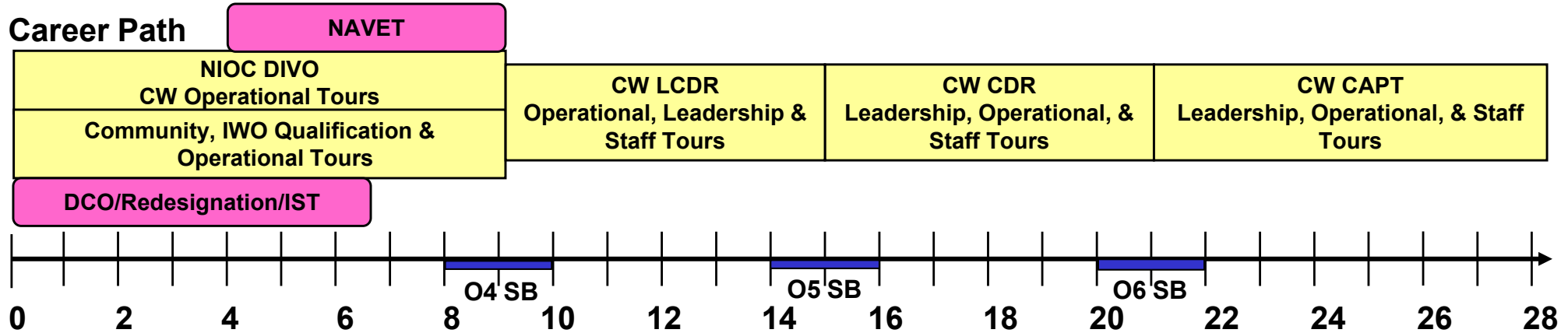

### Typical Billets/Quals

<p><u>Operational</u> NSA/Fleet, Joint/Fleet Integrated Fires/Effects, Active Duty or Reserve IA/MOB, Extended AD (CW) AD Fleet or Squadron Deployment</p>	<p><u>Operational</u> Ops Officer, IA/MOB, Extended AD <u>Leadership</u> CW OIC CW XO CW Dept Head N1/N7 <u>Staff</u> FCC/C10F, NSA, Joint, NAVIFORES REDCEN Staff</p>	<p><u>Operational</u> Ops Officer, IA/MOB, Extended AD <u>Leadership</u> CW CO MAJCOM XO Cross-Slate XO <u>Staff</u> NAVIFORES REDCEN/HQ Staff FCC/C10F, NSA, Space, Joint</p>	<p><u>Operational</u> Recall, IA/MOB, Extended AD <u>Leadership</u> NAVIFORES REDCEN CO MAJCOM CO, Cross-Slate CO <u>Staff</u> NAVIFORES HQ, NAVIFORES REDCEN CSO, FCC/C10F, NSA, Space, Joint</p>
--	--	--	--

<p>CW PQS NLT 3 years IWO NLT 5 years</p>	<p>Advanced degree, IWOIC, Space AQD</p>	<p>JPME I/II, NRUM, R-MCLC, Space AQD</p>
---	--	---



# Cryptologic Warfare Officer

## *Community Values*

- **Sustained superior performance, leadership and expertise in demanding billets and assignments**
- **Evidence of a learning mindset, innovative problem solving and data-driven decision making**
- **Valued Reserve contributions to Navy mission via operational / mobilization assignments and Canvasser Recruiter duty during FY23 and beyond**
- **Valued achievements prior to LIEUTENANT COMMANDER**
  - CW/IWO qualification
  - Division Officer, SIGINT, Joint/Fleet Integrated Fires/Effects, Operations in the Information Environment, inc. EMW, Space tours
  - Completion of a CW related MOB, Afloat Tour (AC), or CW/CYBER AC tour
  - MT&E experience to include Training or Admin Officer
- **Valued achievements prior to COMMANDER**
  - Leadership tour (CW XO, CW OIC)
  - Advanced STEM degree or technical certifications, demonstrated Space proficiency
  - OPS Officer, MOB; operational planning/OLW qualification/experience tours
  - Major staff tours (NAVIFORES HQ/REDCEN, FCC/C10FLT, NSA, Joint)
  - MT&E experience to include Training or Admin Officer
- **Valued achievements prior to CAPTAIN**
  - Leadership tours (CW CO, MAJCOM XO)
  - Continued OPS Experience, MOB tours
  - Major staff tours (NAVIFORES HQ/REDCEN, FCC/C10FLT, NSA, Joint)
  - Space AQD (VS5 or higher)
  - Note: CW Joint Qualification Billets not available for JQO attainment



# Engineering Duty Officer Career Progression

## Career Path

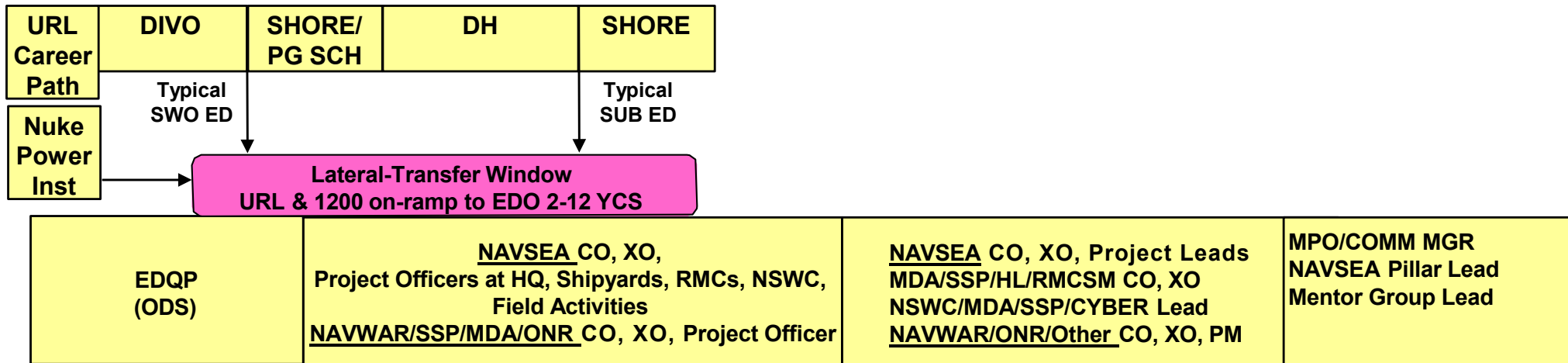

Each individual's EDO career path is tailored based on past experience, accession timing, and education.

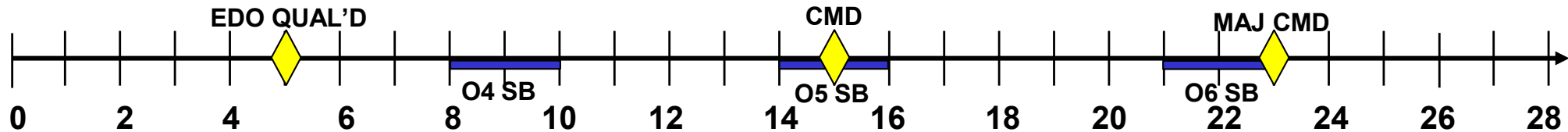

## Typical Billets

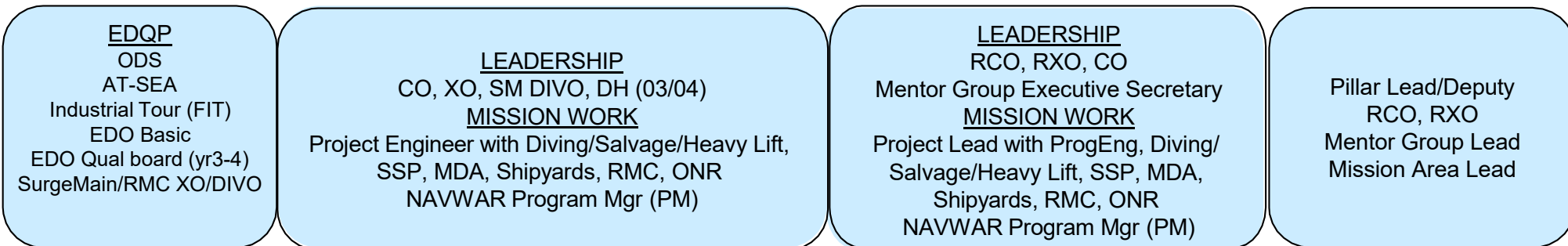



# Engineering Duty Officer

## *Community Values*

- **Sustained superior performance, leadership and expertise in demanding billets and assignments**
- **Evidence of a learning mindset, innovative problem solving and data-driven decision making**
- **Valued Reserve contributions to Navy mission via operational / mobilization assignments and Canvasser Recruiter duty during FY23 and beyond**
- **Valued achievements prior to LIEUTENANT COMMANDER**
  - Advanced technical degree and EDO qualification tour completed
    - Lateral transfers may not be qualification complete
  - SurgeMain / RMC / SY ENG Division Officer, Department Head or Executive Officer
  - Specific technical expertise (diving & salvage, heavy lift, maintenance/repair, strategic systems, missile defense, space) serving as Project Officers in commands utilizing those skills
- **Valued achievements prior to COMMANDER**
  - Commanding Officer or Executive Officer
  - Technical expert in their specific mission area
  - Community engagement: - Recruiting, National SurgeMain/RMC (Finance, Training, Communications, Admin), Junior Officer Advisory Panel, ED Qualification Program (JO Training and Mentoring, EDO Community Event Support), etc.
  - Joint Professional Military Education (JPME) is desirable but not required
- **Valued achievements prior to CAPTAIN**
  - Commanding Officer
  - Technical leadership in mission or community national-level roles when not in command
  - Community engagement: ED Qualification Program (JO training and mentoring, Counseling/Qualification Officer, mock boards), Individual Development Plan development, EDO community issue engagement at the national level (e.g. Workshop Lead, Strategic Planning, Course Director, etc.)



# Explosive Ordnance Disposal Officer

## Career Progression

### Career Path

AC Init Trng	AC Plt Ldr	AC Plt Comp Cdr	AC Shore	Operational: XO Tour/CO Tour  Staff: TYCOM/ Numbered Fleet/Joint Tour	Operational: XO Tour/CO Tour  Staff: TYCOM/ Numbered Fleet/Joint Tour	Operational: O6 CO Tour  Staff: Major Staff CCDR	Operational: MAJCOM SEQ MAJCOM Staff: POST CMD Major Staff Joint Tour
		Initial RC Tours					

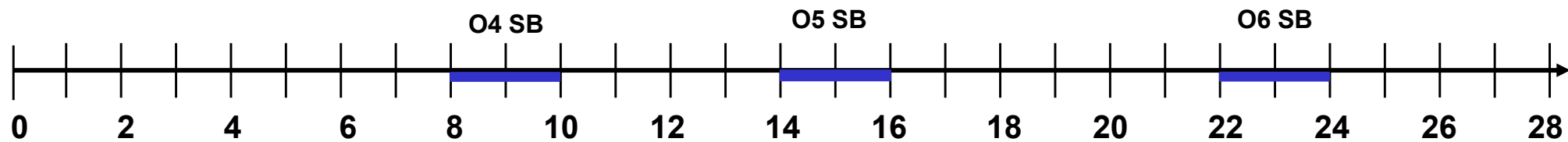

### Typical Billets

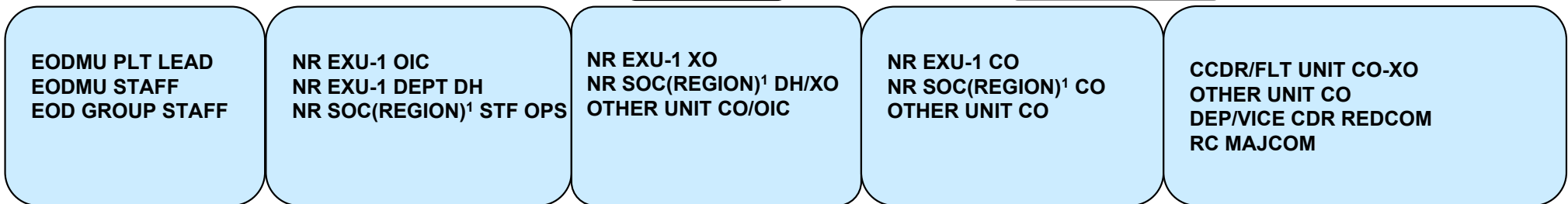

1) Includes SOCAFRICA, SOCCENT, SOCEUROPE, SOCKOREA, SOCNORTH, SOCPACIFIC and SOCSOUTH



# Explosive Ordnance Disposal Officer

## *Community Values*

- **Sustained superior performance, leadership and expertise in demanding billets and assignments**
- **Evidence of a learning mindset, innovative problem solving and data-driven decision making**
- **Valued Reserve contributions to Navy mission via operational / mobilization assignments and Canvasser Recruiter duty during FY23 and beyond**
- **Valued achievements at all paygrades**
  - Dual Warfare Qualified (SWO and EOD) for those commissioned before 2006
  - NRU CO/OIC qualified (AQD 2N1)
  - Graduate education
  - Joint Qualified Officer
- **Valued achievements prior to LIEUTENANT COMMANDER**
  - Sustained outstanding performance through active PLT OIC tours
  - NR EXU-1 EOD/NSW related mobilization or deployment while on active duty (prior to SELRES)
- **Valued achievements prior to COMMANDER**
  - Advanced Degree
  - JPME I
  - XO / DH billet at an EOD/NSW unit (EXU, NECC, NSW)
  - NR EXU-1 or EOD/NSW related mobilization or a mobilization to an operational theater
- **Valued achievements prior to CAPTAIN**
  - JPME I
  - CO / XO billet at an EOD/NSW unit (EXU, NECC, NSW, Joint Staff, CCDR)



# Explosive Ordnance Disposal Officer (TAR)

## Career Progression

### Career Path

<b>Fleet Experience Tours and Qualifications</b> (Diver, EOD, 1 <sup>st</sup> & 2 <sup>nd</sup> EOD Officer Tours)	<b>Operational: DH Reserve Mgt:</b> NRC/RTAG XO/TO	XO/CO ECH 1-4 Navy/Joint Staff Jr. Service College	O5 Command Joint/RPD ECH I-4 Navy/Joint Staff Sr. Service College	O6 Command/MAJCOM Major Staff Joint/RPD
--	--	---	---	---

Graduate Education  
JPME I

JPME II  
JCWS-H

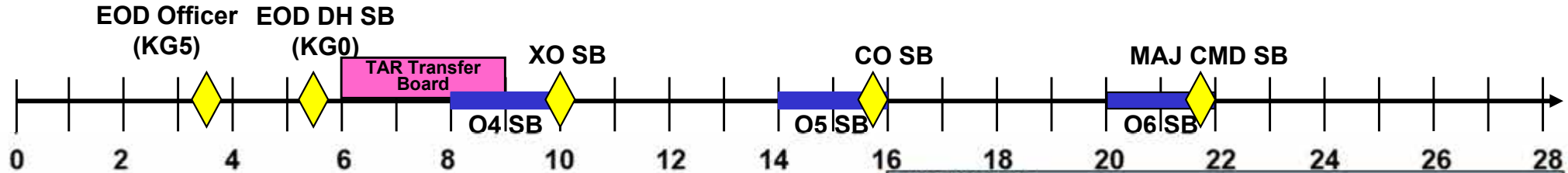

#### RESERVE MANAGEMENT:

NRC CO – 24-36 Month Tours  
Major Staff (OCNR/CNRF/REDCOM/RPD/NECC/NSW/SOCOM/TSOC)  
O5/O6 CMD: EXU-1, NRC, RTAG, NSW, EOD  
XO: EXU-1, NRC, RTAG, NSW, EOD

#### ACRONYMS

CEODD:	Center for EOD and Diving
EODMU:	EOD Mobile Unit
EODTEU:	EOD Training and Evaluation Unit
EXU-1:	Expeditionary Exploitation Unit One
JSOC:	Joint Special Operations Command
JTF-SREC:	JTF Special Reconnaissance Enabling Command
MDSU:	Mobile Diving and Salvage Unit
NEDU:	Navy Experimental Diving Unit
NDSTC:	Navy Diving and Salvage Training Center
NSEOD:	Naval School EOD
NSWC:	Naval Special Warfare Command
NSW:	Naval Special Warfare
TSOC:	Theater Special Operations Command (SOCEUR, SOCNORTH)



# Explosive Ordnance Disposal Officer (TAR)

## *Community Values*

- **Sustained superior performance, leadership and expertise in demanding billets and assignments**
- **Evidence of a learning mindset, innovative problem solving and data-driven decision making**
- **EOD TAR does not have an operational pipeline; expect to see members in a variety of operational and reserve management jobs. Varied career paths are valued**
- **Graduate education in any field is valued regardless of source or method of achievement (e.g. civilian institution, NWC, NPS, distance learning)**
- **Valued achievements prior to LIEUTENANT COMMANDER**
  - Served/Serving Department Head
  - Attained both EOD OFFICER (KG5) and EOD DH (KG0) qualifications
  - Active Component PLT OIC tours
  - Recognized top performer in tactical/operational assignments (NSW, EODMU, MDSU, EXU-1)
- **Valued achievements prior to COMMANDER**
  - Served/Serving XO(Afloat or Ashore) or Served/Serving O-4 CO NRC
  - Sustained Superior Performance on Navy/Joint ECH 1-4 Staffs
  - Top Performer in Operational and Reserve Management Leadership Positions
- **Valued achievements prior to CAPTAIN**
  - Served/Serving-O-5 CO (Afloat or Ashore)
  - Major Staff and Joint Assignments (JTF-SREC, OPNAV, OCNR, NPC, CNRFC, NSWC, NECC, OSD, JSOC, USSOCOM, TSOC (SOCEUR, SOCNORTH, etc.), GCC)
  - Top Performer in Operational and Reserve Management Leadership Positions
  - Top performer in screened/nominative positions



# Fleet Support Officer

## Career Progression

### Career Path

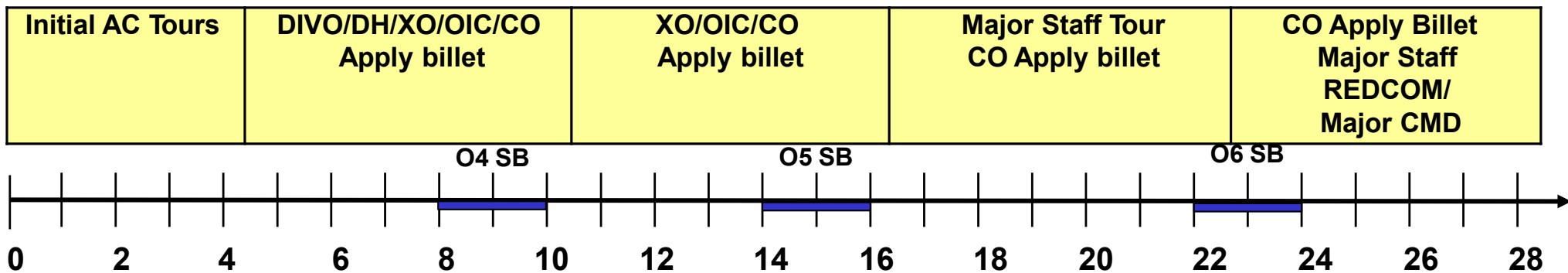

### Typical Billets

Space and Electronics Warfare  
OPNAV/Major Staff  
Echelon 3/4 Staff  
Logistics Support  
Fleet Staffs  
BUPERS Staff  
ONR/NRL Staff

Space and Electronics Warfare  
OPNAV/Major Staff  
Echelon 3/4 Staff  
Logistics Support  
Fleet Staffs  
BUPERS Staff  
REDCOM Staff  
ONR/NRL Staff

REDCOM/Major CMD Deputy  
Space and Electronics Warfare  
OPNAV/Major Staff  
Echelon 3/4 Staff  
Logistics Support  
Fleet Staffs  
BUPERS Staff  
ONR/NRL Staff



# Fleet Support Officer

## *Community Values*

- **Sustained superior performance, leadership and expertise in demanding billets and assignments**
- **Evidence of a learning mindset, innovative problem solving and data-driven decision making**
- **Valued Reserve contributions to Navy mission via operational / mobilization assignments and Canvasser Recruiter duty during FY23 and beyond**
- **Valued achievements at all paygrades**
  - Consistent leadership assignments across multiple specialties
- **Valued achievements prior to LIEUTENANT COMMANDER**
  - Successful DIVO / DH leadership positions in high profile / high OPTEMPO units
- **Valued achievements prior to COMMANDER**
  - Successful CO / XO / DH leadership positions in high profile / high OPTEMPO units
- **Valued achievements prior to CAPTAIN**
  - Successful CO / XO leadership positions in high profile / high OPTEMPO units
- **Other valued achievements**
  - Advanced degree
  - JPME I/II/ Joint Tour / IA JT OPS
  - Command/OIC qualified (AQD 2N1)



# Foreign Area Officer Career Progression

## Career Path

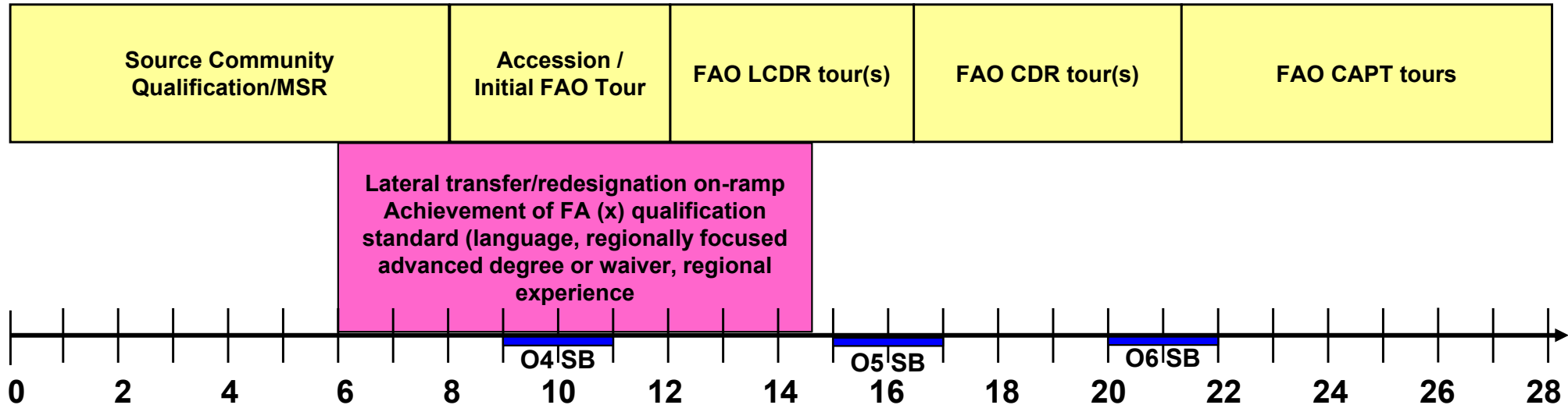

## Typical Billets / Quals:

The RC FAO community provides policy, plans, and strategy professionals enabled by language, culture, and regional expertise qualifications for ally and partner engagement to Joint/Navy staffs, U.S. Embassy Defense Attache Offices, and Security Cooperation Offices worldwide ISO planning and execution of international engagement and security cooperation programs and activities.

### Billets/Quals for LCDR/O4

- 1) Reserve assignment commensurate with rank (FAO SME, DH)
- 2) Mobilization, ADOS, or other op support (> 6mos) in a FAO billet
- 3) Progress towards leadership, planning, or LREC qualifications
- 4) Progress towards FA (x) qualification

### Billets/Quals for CDR/O5

- 1) Reserve assignment commensurate with rank (FAO SME, CO/XO)
- 2) Mob, ADOS or other op support in a FAO billet
- 3) Completion of leadership, planning, or LREC qualifications
- 4) Completion of FA(x) qualification

### Billets/Quals for CAPT/O6

- 1) Reserve assignment commensurate with rank
- 2) Mob, ADOS, or other op support in a FAO billet
- 3) Completion of joint and additional qualifications
- 4) Community leadership (COS, DCOS, mentor)



# Foreign Area Officer

## *Community Values*

- **Sustained superior performance, leadership and expertise in demanding billets and assignments**
- **Evidence of a learning mindset, innovative problem solving and data-driven decision making**
- **Valued Reserve contributions to Navy mission via operational / mobilization assignments and Canvasser Recruiter duty during FY23 and beyond**
- **Valued achievements prior to LIEUTENANT COMMANDER**
  - Warfare qualified in source community
- **Valued achievements prior to COMMANDER**
  - Leadership commensurate with rank
  - Completion of at least 2 of 3 FAO regional qualification requirements:
    - Proficiency in at least one foreign language (2/2 required to meet standard)
    - Regional expertise (six months required)
    - International relations focused master's degree
  - JPME Phase 1
- **Valued achievements prior to CAPTAIN**
  - Completion of FA(X) qualification AQD
  - Leadership commensurate with rank (Reserve Leadership CO/XO; Joint Director; or primary DH. Recall/Mob/ADOS: Senior Defense Official; Security Cooperation Office Chief; Theater Security Cooperation Cell Lead/Staff)



# Human Resources Officer Career Progression

## Notional Career Path

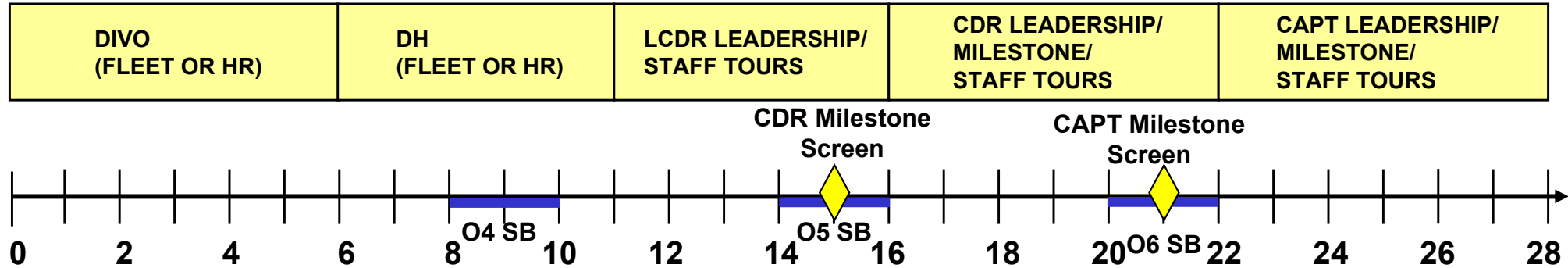

## Typical Billets

DH/DIVO/OIC/Staff Tour  
PERS/Training/Pay  
Officer/Staff Ops/Plans  
Joint Experience

DH/OIC/XO/Milestone  
PERS/MPWR Staff and Mgt  
Admin/Training/Pay  
Resource Mgt  
Joint Education/Experience

CDR Milestone  
XO/OIC/CO/Milestone  
PERS/MPWR Analysis & Plans  
Resource Mgt  
Major Staff  
Joint Education/Experience

CAPT Milestone  
CO/Major Command/Major  
Staff/Deputy/Milestone  
Staff Ops/Plans  
Joint Tour/Experience

- Develop Core competency areas: Development, Management, Requirements
- MPT&E leadership positions within the Fleet and major staffs
- Reserve leadership positions that enable reserve warfighting readiness in support of Reserve Force design, training, mobilization, & development

CO/XO and Milestone screening for CDRs and CAPTs occurs via APPLY Board



# Human Resources Officer

## *Community Values*

- **Sustained superior performance, leadership and expertise in demanding billets and assignments**
- **Evidence of a learning mindset, innovative problem solving and data-driven decision making**
- **Valued Reserve contributions to Navy mission via operational / mobilization assignments and Canvasser Recruiter duty during FY23 and beyond**
- **Service within the 1205 community in roles including mentorship, Executive Steering Committee (ESC) involvement, Reserve Regional Captain, HR regional positions, and Direct Commission Officer Interviewer or board support**
  
- **Valued achievements prior to LIEUTENANT COMMANDER**
  - Attainment of source community qualifications
  
- **Valued achievements prior to COMMANDER**
  - Successful leadership tours and/or periods of active duty such as mobilization, ADOS, or recall in N1 enterprises throughout the Fleet
  - Master's degree in subspecialties including Financial Management, Manpower Systems Analysis, Education and Training Management, Operations Analysis, Information Systems and Technology (3XXX SSP preferred)
  - Attainment of command qualification and screening (2N1 AQD)
  - Certification including PHR, SPHR, GPHR, CPT, CPLP, CDFM, CDFM-A, CISSP or GSLC
  
- **Valued achievements prior to CAPTAIN**
  - CDR HR command/milestone assignments and demonstrated Reserve leadership
  - Periods of active duty such as mobilization, ADOS or recall in N1 enterprises throughout the Fleet
  - Master's degree in subspecialties including Financial Management, Manpower Systems Analysis, Education and Training Management, Operations Analysis, Information Systems and Technology (3XXX SSP preferred)
  - Attainment of command qualification and screening (2N1 AQD)
  - Professional certification including PHR, SPHR, GPHR, CPT, CPLP, CDFM, CDFM-A, CISSP or GSLC
  - JPME I completed



# Human Resources Officer (TAR)

## Career Progression

### Career Path

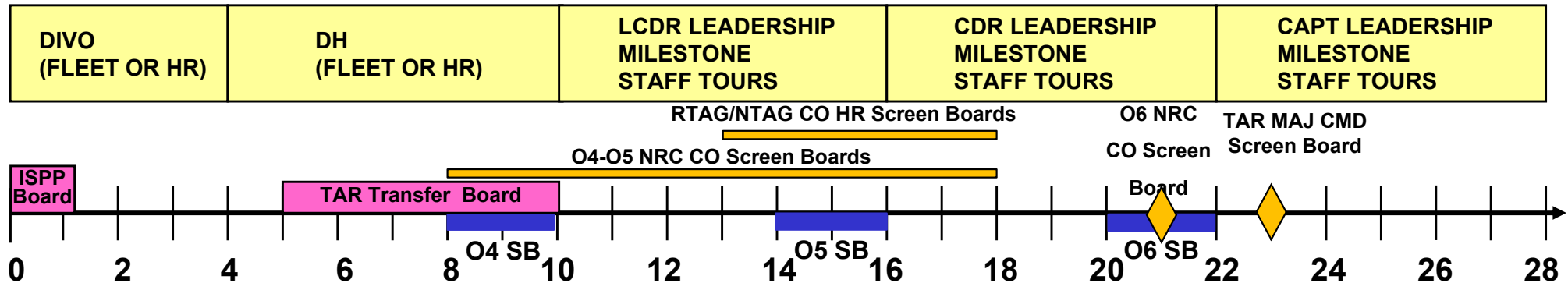

### Typical Billets

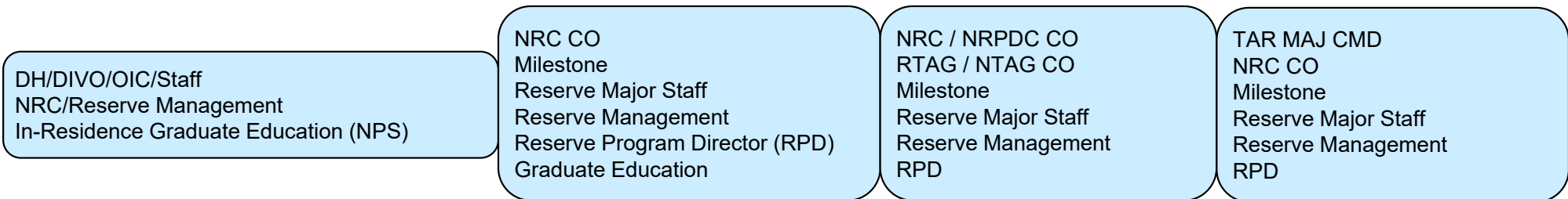

**Develop Core Competency Areas: Development, Management, Recruiting, Requirements**

**Develop Sub-specialty Experience: Financial Management (311X), Manpower Systems Analysis (3130), Education and Training Management (3150), Operations Analysis (321X), Information Technology (620X), Requirements Management (6511)**

Command screening occurs annually. LT-CAPT may screen for Reserve Command via the Navy Reserve Shore Command Qualification Program. CDR-CAPT may also screen for HR Command Recruiting billets via the HR Command Qualification Program. CAPT may be eligible to screen for TAR MAJ CMD via the TAR MAJ CMD SCREEN Board



# Human Resources Officer (TAR)

## *Community Values*

- **Sustained superior performance, leadership and expertise in demanding billets and assignments**
- **Evidence of a learning mindset, innovative problem solving and data-driven decision making**
- **Valued achievements prior to LIEUTENANT COMMANDER**
  - Attainment of source community qualifications
- **Valued achievements prior to COMMANDER**
  - NRC CO, Milestone and Major Reserve Staff, RPD, and OIC tours
  - Master's degree in subspecialties including Financial Management, Manpower Systems Analysis, Education and Training Management, Operations Analysis, Information Systems and Technology (3XXX SSP preferred)
  - HR Subspecialty experience: 311X, 3130, 3150, 321X, 620X, 6511
  - Attainment of command qualification and screening (2D1 AQD)
  - Professional Certification including PHR, SPHR, GPHR, CDFM, CDFM-A, CISSP or GSLC
- **Valued achievements prior to CAPTAIN**
  - NRC/NRPDC CO, RTAG/NTAG CO, Milestone and Major Reserve Staff tours
  - Master's degree in subspecialties including Financial Management, Manpower Systems Analysis, Education and Training Management, Operations Analysis, Information Systems and Technology (3XXX SSP preferred)
  - Proven subspecialist: 311X, 3130, 3150, 321X, 620X, 6511
  - Successful completion of command as documented by AQD (e.g., CE3, CE4, CE5)
  - Professional Certification including PHR, SPHR, GPHR, CDFM, CDFM-A, CISSP or GSLC



# Information Professional Officer

## Career Progression

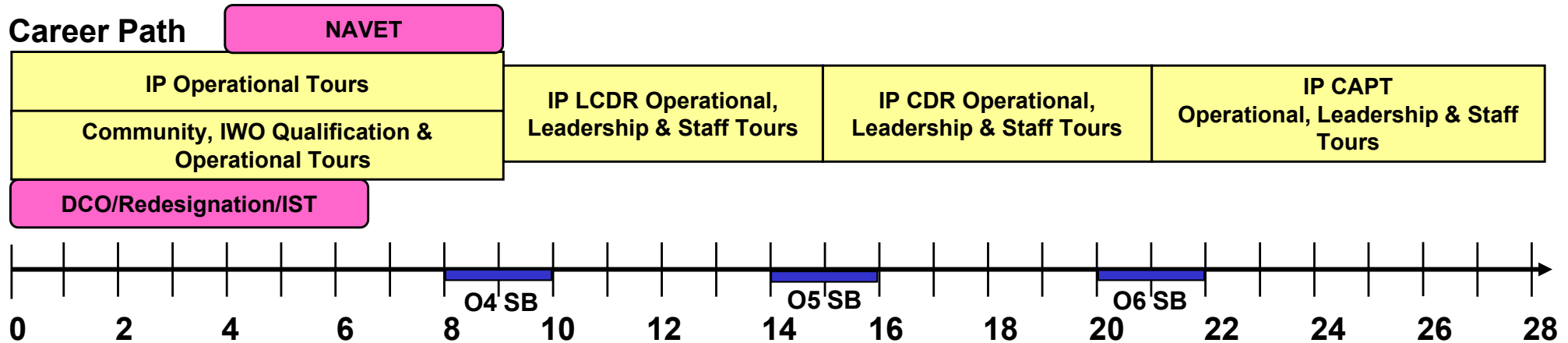

### Typical Billets/Quals

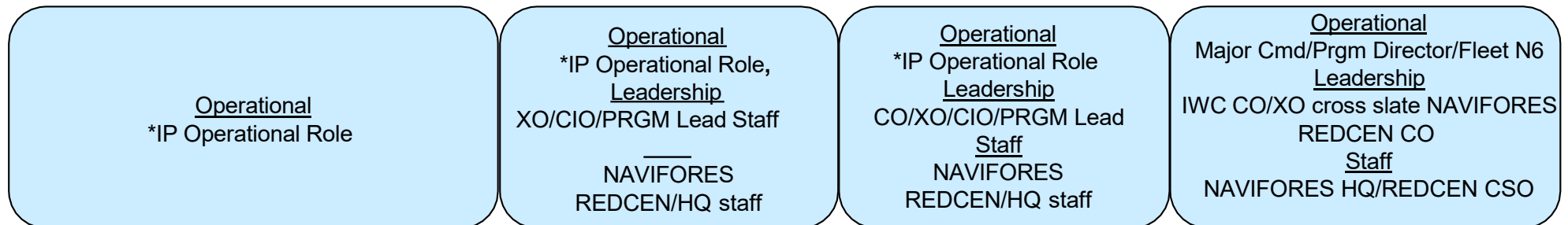

\* IP Operational Roles would include CYBER, Info Systems, Info Assurance, Command and Control, Communications, Combat Systems, Intelligence/Surveillance/Reconnaissance, Space, Knowledge Management, Information Management, Fleet Staff/MOC

IP PQS NLT 3 years  
IWO NLT 5 years  
MSOC

Advanced technical degree,  
Joint C4 Planner's  
Course

IP IQ, VS5,  
IWOIC

IP AQ, JCWS-H/JPME I  
Joint C4I Officer and Staff Course, NRUM, R-MCLC

IP Community Leadership (National Training Team, Symposium Lead, Mentoring, Recruiting, REDCEN Lead IP, etc.)



# Information Professional Officer

## *Community Values*

- **Sustained superior performance, leadership and expertise in demanding billets and assignments**
- **Evidence of a learning mindset, innovative problem solving and data-driven decision making**
- **Valued Reserve contributions to Navy mission via operational / mobilization assignments and Canvasser Recruiter duty during FY23 and beyond**
  
- **Valued achievements prior to LIEUTENANT COMMANDER**
  - Attainment of IP Basic and IWO qualifications
  - Competitive operational tours demonstrating superior performance and fundamental knowledge of cyber operations, C4I, and information technology
  - Advanced certifications in networking, security, and cloud such as CISSP, CEH, or anything from Cisco, SANS/GIAC, AWS, Azure, or GCP
  - Progress towards a technical Master's degree
  
- **Valued achievements prior to COMMANDER**
  - OIC, program manager, or XO leadership tour
  - Advanced Cyber Security Workforce qualifications (AQD GA7) and technical expertise in systems management, acquisition, and Space
  - Advanced degree in STEM-related field, advanced technical certifications, or DoD CIO certificate
  - IP-related OLW experience
  - Space AQD VS5 or higher
  
- **Valued achievements prior to CAPTAIN**
  - CO, program manager, CIO, or equivalent tour as an O-5
  - NAVIFORES national/REDCEN tour
  - IP community leadership roles
  - Space AQD VS5 or higher
  - JPME I



# Intelligence Officer Career Progression

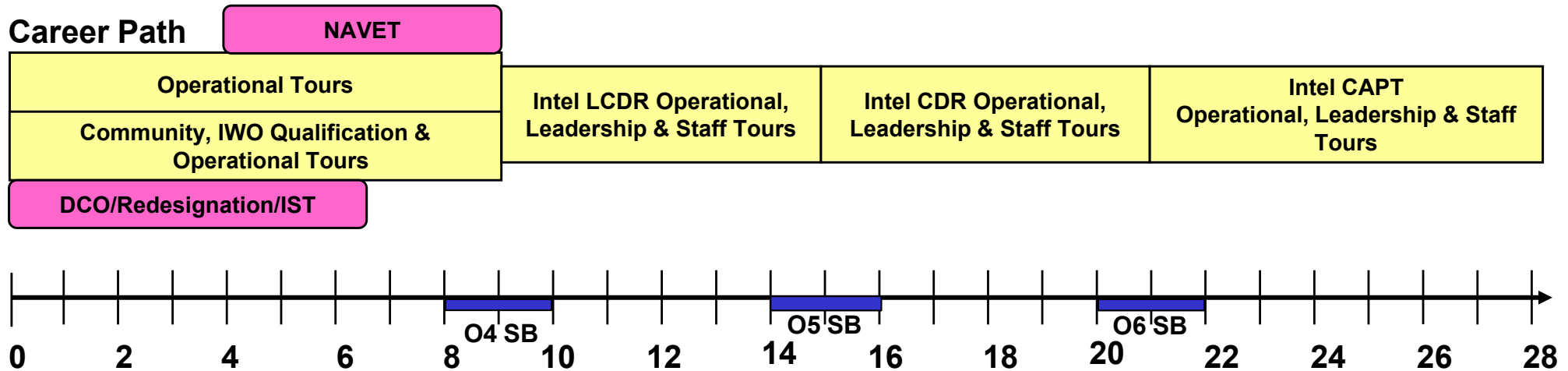

## Typical Billets/Quals

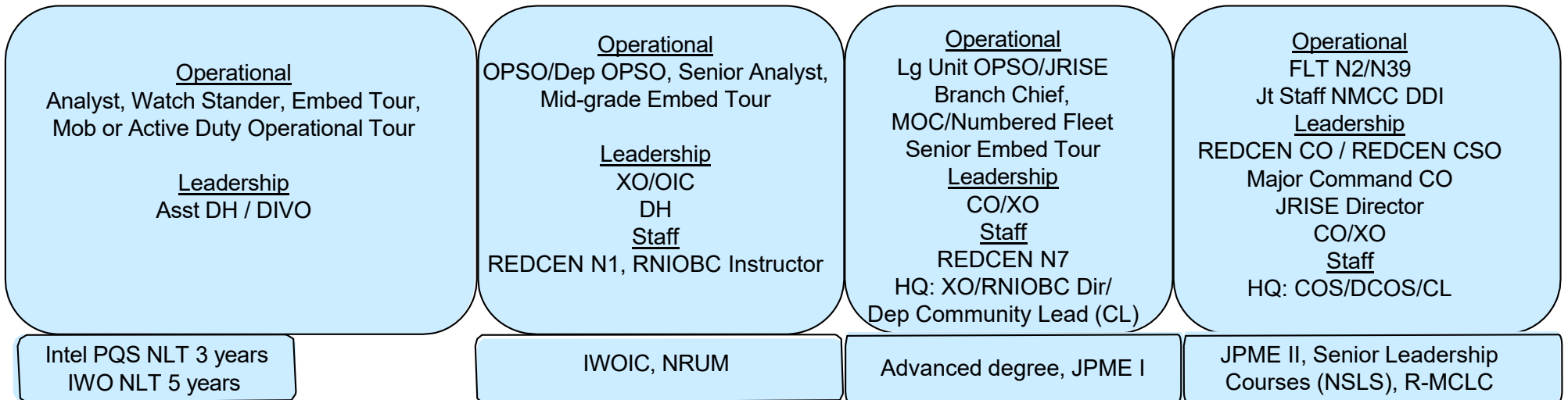



# Intelligence Officer

## *Community Values*

- **Sustained superior performance, leadership and expertise in demanding billets and assignments**
- **Evidence of a learning mindset, innovative problem solving and data-driven decision making**
- **Valued Reserve contributions to Navy mission via operational / mobilization assignments and Canvasser Recruiter duty during FY23 and beyond**
- **Intelligence competencies for warfighting advantage:** OPINTEL, HUMINT (e.g., attaché, debriefing), SIGINT/Cyber, Technical Intel (e.g., foreign materiel exploitation), NSW Intel, Collection Management, Space, Targeting, and Expertise on Adversaries (particularly China). Proficiency may be gained through unit tours, schools, mobilizations, and orders
- **Intel mobilization or active duty operational tour at any rank**
- **Valued achievements prior to LIEUTENANT COMMANDER**
  - Qualified as an Intelligence and Information Warfare Officer
  - Advanced proficiency in an Intelligence competency
  - Leadership as a unit Division Officer, Asst Dept Head, or similar O-3 billet
- **Valued achievements prior to COMMANDER**
  - Successful performance in an O-4 leadership billet: APPLY-selected OIC/XO, unit Department Head, Reserve Naval Intelligence Officer Basic Course (RNIOBC) instructor, or REDCEN/Ech IV staff position
  - Advanced proficiency in two or more Intelligence competencies
- **Valued achievements prior to CAPTAIN**
  - Successful performance in an APPLY-selected O-5 leadership billet: unit CO/OIC/XO, CNIFR HQ billet, or REDCEN/Ech IV staff billet
  - Leadership in two or more Intelligence competencies
  - Superior performance in both Navy and Joint units
  - Advanced degree, JPME I



# Maritime Cyber Warfare Officer

## Career Progression

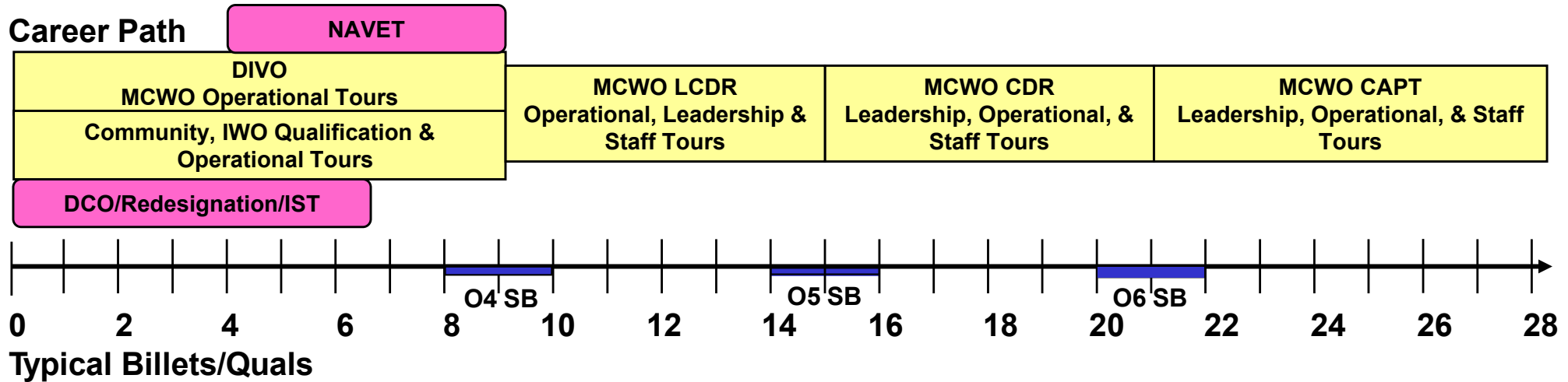

<p><u>Operational</u> FCC/C10F HQ, CWG-6, NCWDG, NIOC, NSA, CYBERCOM, NNWC Active Duty or Reserve IA/MOB, Extended AD (MCWO) AD Cyber Mission/Protection Team support</p>	<p><u>Operational</u> Ops Officer, CTOC, Special Projects, IA/MOB, Extended AD <u>Leadership</u> MCWO OIC MCWO XO MCWO Dept Head N1/N7 <u>Staff</u> FCC/C10F, CPT, NCDOC CYBERCOM</p>	<p><u>Operational</u> Ops Officer, CTOC, Special Projects, IA/MOB, Extended AD <u>Leadership</u> MCWO CO MCWO XO MAJCOM XO <u>Staff</u> FCC/C10F, CPT, NCDOC, NNWC, CYBERCOM</p>	<p><u>Operational</u> Recall, IA/MOB, Extended AD <u>Leadership</u> MCWO CO NR C10F XO <u>Staff</u> FCC/C10F NAVIFORES HQ</p>
COPC, USCC PQS NLT 3 years, IWO NLT 5 years	Advanced Degree, JPME I, MOPC, IWOIC	JPME II, JQO, NRUM, R-MCLC	

**Constructive Entry Credit:** SECNAV authorized MCWO for Constructive Grade Credit, which allows for MCWOs to be accessed at paygrades above O1/ENS due to Experience and/or Education

**Redesignation:** Community established in FY23. All initial accessions are redesignations from other communities. NAVET/DCO incorporated into the FY24 Accession Plan



# Maritime Cyber Warfare Officer

## *Community Values*

- **Sustained superior performance, leadership and expertise in demanding billets and assignments**
- **Evidence of a learning mindset, innovative problem solving and data-driven decision making**
- **Valued Reserve contributions to Navy mission via operational / mobilization assignments and Canvasser Recruiter duty during FY23 and beyond**
- **Valued achievements prior to LIEUTENANT COMMANDER**
  - Superior performance/qualification in Cyber Mission Force (CMF) operational tour
  - Information Warfare Qualification Complete
  - Active Duty or Reserve IA/MOB, AD Cyber Mission/Protection Team Support
  - Progress toward Advanced Degree in Cyber related field
  - Continuing education demonstrated through Cyber Industry certifications (Includes, but not limited to: PenTest+, CEH, OSCP)
- **Valued achievements prior to COMMANDER**
  - Superior performance CMF Ops Officer, IA/MOB, Extended Active Duty
  - Superior performance in CMF Leadership tour MCWO OIC/XO, MCWO Dept Head, N1, N7
  - Master's Degree in Cyber related field Complete
  - Continuing education demonstrated through Cyber Industry certifications (Includes, but not limited to: PenTest+, CEH, OSCP)
  - JPME I
- **Valued achievements prior to CAPTAIN**
  - Superior performance in senior CMF Ops Officer, IA/MOB, Extended Active Duty
  - Superior performance in CMF Leadership tour MCWO XO, MCWO CO
  - Superior Performance in NAVIFORES Staff
  - JPME I



# Maritime Space Officer Career Progression

Career Path

NAVET

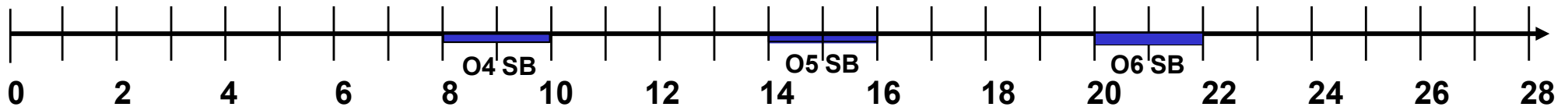
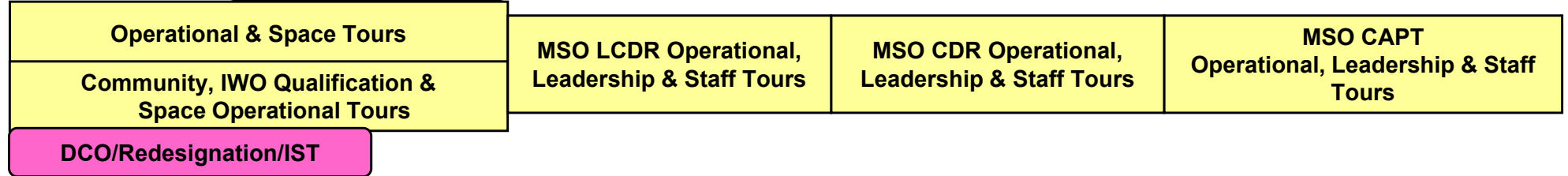

Typical Billets/Quals

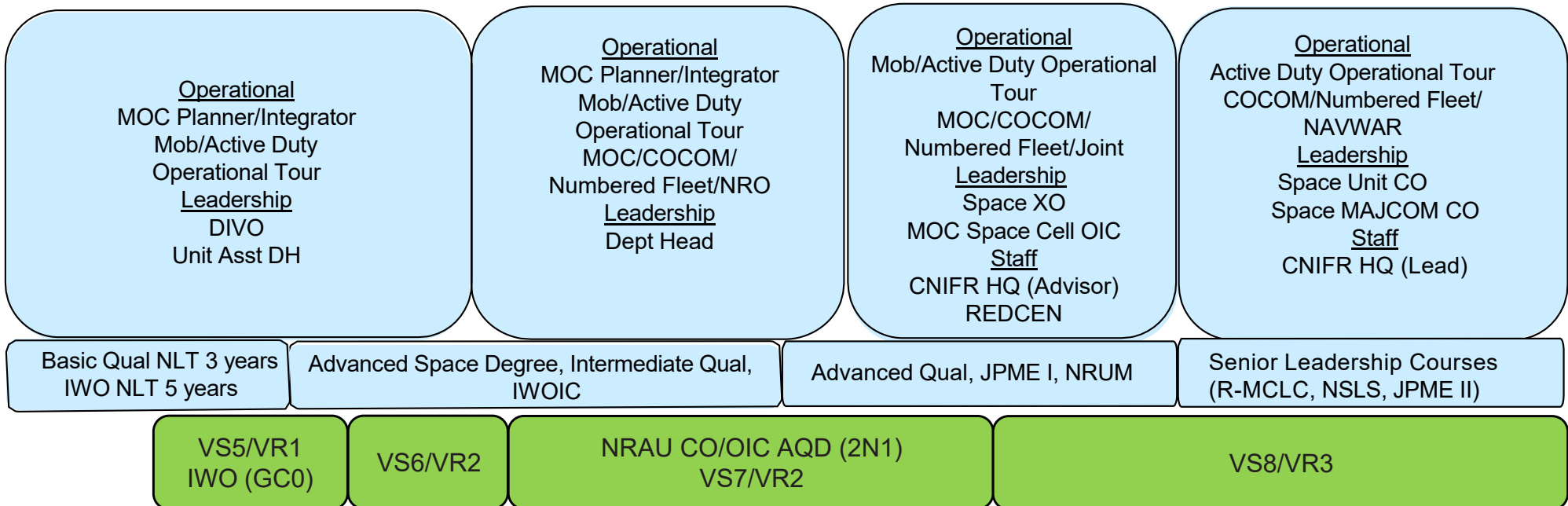



# Maritime Space Officer

## *Community Values*

- **Sustained superior performance, leadership and expertise in demanding billets and assignments**
- **Evidence of a learning mindset, innovative problem solving and data-driven decision making**
- **Valued Reserve contributions to Navy mission via operational / mobilization assignments and Canvasser Recruiter duty during FY23 and beyond**
- **Valued achievements prior to LIEUTENANT COMMANDER**
  - Superior performance in space operational tour and prior community operational/space tours
  - MSO Basic and Information Warfare Qualification Complete
  - Completion of One Space JQR (Fleet MOC, NRO, NAVSPACE, SPACECOM)
  - Space Intermediate Qualification (Space AQD VS6 / VR2 or higher)
- **Valued achievements prior to COMMANDER**
  - MT&E experience as a Space Unit DH
  - Maritime Space Operations Integration Course (MSOIC) Complete
  - NRU CO/OIC qualified (AQD 2N1)
  - Superior performance in Intermediate Space Operational tour
  - Advanced Space Qualification (Space AQD VS7 / VR2 or higher)
  - Leadership tour (Space DH, MOC Space Cell Deputy OIC)
  - Master's Degree or higher
- **Valued achievements prior to CAPTAIN**
  - Demonstrated superior performance and leadership as XO/Space Cell OIC
  - Standout performance while serving in positions of influence or leadership at operational commands and staffs
  - Space Advanced Qualification (Space AQD VS7/8 or VR3)
  - Leadership tours (MOC Space Cell OIC, Space XO, Space Cadre Advisor)
  - JPME I



# Oceanography Officer

## Career Progression

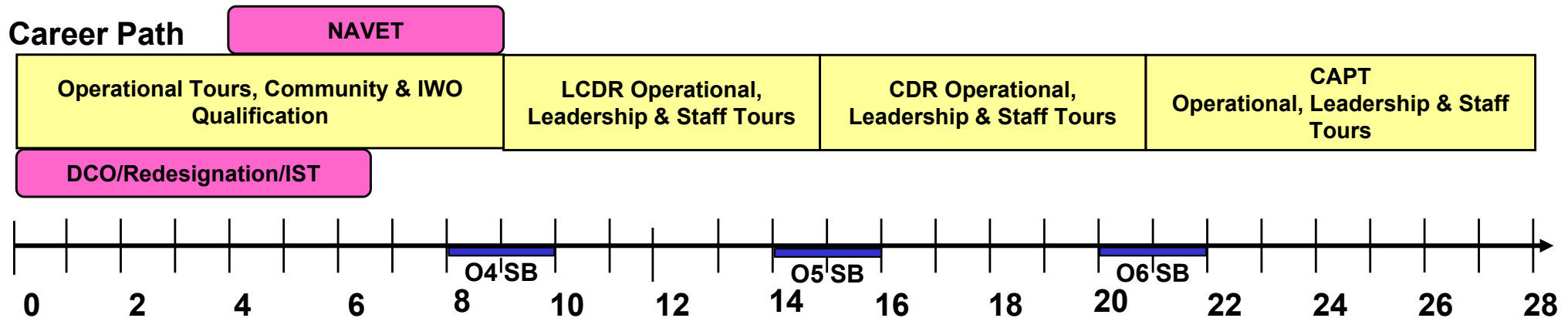

### Typical Billets / Quals

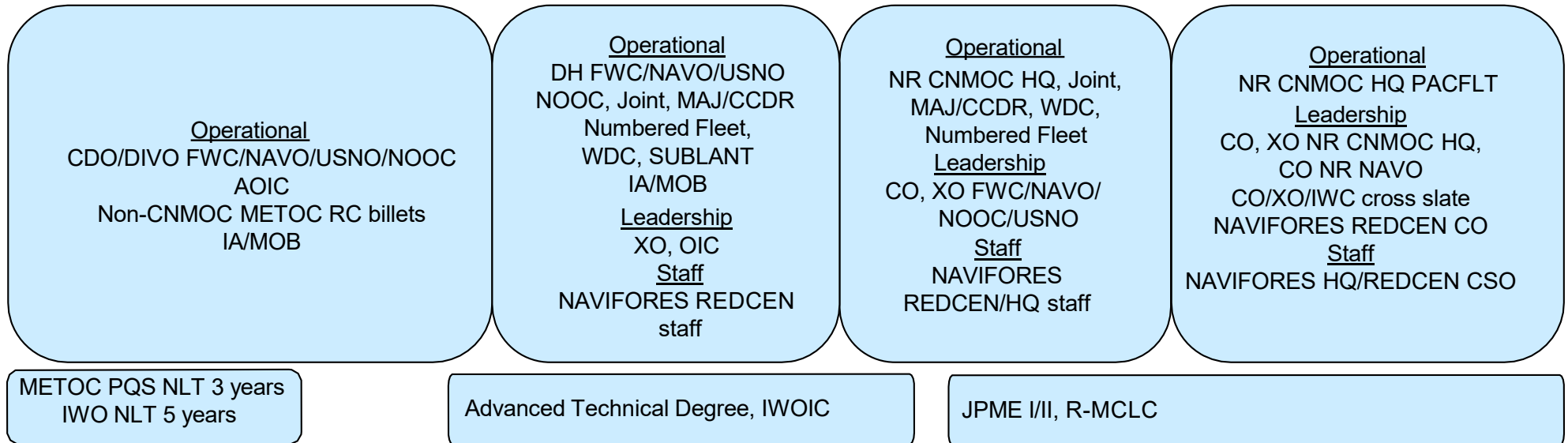



# Oceanography Officer

## *Community Values*

- **Sustained superior performance, leadership and expertise in demanding billets and assignments**
- **Evidence of a learning mindset, innovative problem solving and data-driven decision making**
- **Valued Reserve contributions to Navy mission via operational / mobilization assignments and Canvasser Recruiter duty during FY23 and beyond**
- **Valued achievements prior to LIEUTENANT COMMANDER**
  - METOC PQS Complete / IWO qualification
  - Leadership experience in a unit DIVO/DH position
  - Demonstrated operational OCEANO experience at NR CNMOC unit, fleet staff or WDC
- **Valued achievements prior to COMMANDER**
  - Superior performance in reserve unit leadership tour (XO, OIC)
  - Demonstrated proficiency in operational support to CNMOC OCEANO missions
  - Demonstrated proficiency in staff OCEANO missions at fleets, WDCs, or TYCOMs
  - Completion of an OCEANO MOB or other long term active duty operational OCEANO assignment
- **Valued achievements prior to CAPTAIN**
  - Superior performance in NR unit command tour(s)
  - Superior performance in positions of OCEANO leadership and influence (Numbered Fleet, WDC's)
  - Operational OCEANO training/experience at joint service command or major fleet exercise
  - Reserve TYCOM experience in NAVIFORES REDCEN or HQ billet
  - JPME I



# Permanent Professional Recruiter Officer (TAR)

## Career Progression

### Career Path

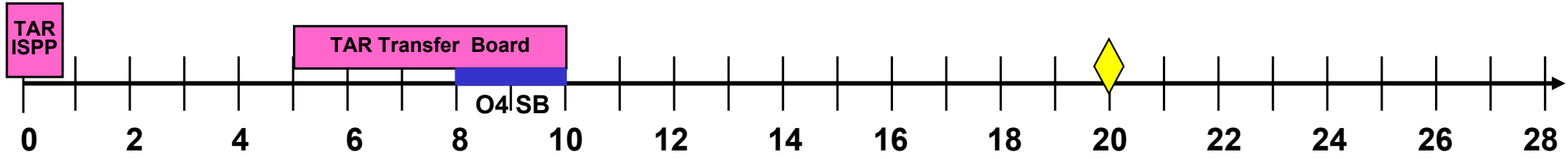

### Typical Billets

Permanent Professional Recruiting Tour(s)  
 NRRC HQ, \*RTAG, Area and Site Production and Staff Tour(s)

Fleet Assignments  
 DH/DIVO/OIC/Staff  
 Recruiting Tour  
 Reserve Management

- Develop Core Competency Areas: Recruiting, Development, Management, Requirements
- Develop Sub-specialty Experience: General Management (3XXX)
- Promotion to CDR requires community transition and change of designator

\*Reserve Talent Acquisition Group (RTAG)



# Permanent Professional Recruiter Officer (TAR)

## *Community Values*

- **Sustained superior performance, leadership and expertise in demanding billets and assignments**
- **Evidence of a learning mindset, innovative problem solving and data-driven decision making**
- **Valued achievements at all paygrades**
  - Sustained Superior performance in meeting assigned recruiting attainment goals
  - Professional HR certifications in disciplines to include: PHR, SPHR, and GPHR



# Public Affairs Officer

## Career Progression

### Career Path

DCO	NAVET / Redesignation / IST		
NAVET: Initial AC PA/staff tours	XO/AOIC Department Head IMA	O5 Milestone CO/OIC Other AOIC/XO IMA	O6 COs, COS CHINFO, NPASE HQ Senior IMA
AO, DIVO, DH, Asst. DH			
Tactical PA training/foundations	Unit leadership, increased operational focus	Strategic advisor, community leadership	

\*Community collateral duty appointments enhance leadership and community management proficiencies



### Priority Billets\*

NPASE CHINFO USFF CPF	<u>Operational:</u> #Fleets, CPF, USFF, NPASE  <u>Staff:</u> NAVCO, CHINFO, NAVINFO	<u>Operational:</u> XO: #Fleets*, NPASE West*, NPASE East* AOIC:JPASE  <u>Operational DH:</u> #Fleets, CPF, USFF, CNE, NPASE HQ  <u>CHINFO PA Unit DH:</u> CHINFO, N3/N5 Plnr*, NAVCO, NAVINFO  <u>Staff PAO:</u> Joint Staff, CCMD	<u>Milestone-eligible:</u> CO/OIC: C7F*, C6F*, C5F*, C2F*, JPASE*, NPASE West*, NPASE East* XO: CPF*, USFF*, CNE*  <u>Unit Leadership:</u> XO: CHINFO, NPASE HQ, NAVCO CO/OIC: NAVINFO West, Type Command IMAs  <u>Staff PAO:</u> Joint Staff, OSD, CCMD, CNIFR, REDCOM	<u>Operational:</u> CO: CPF*, USFF, CNE*  <u>Unit Leadership:</u> CO: CHINFO*, NPASE HQ*, NAVCO*  <u>Community/Force Management:</u> COS* (Post-Command), CAG*  <u>Joint PAO:</u> IPC*, Other CCMDs, Joint Staff
--------------------------------	---	--	---	--

### Expected/Valued Quals

ODS	PACS-Q NOBC 2412	NRAU CO/OIC AQD (2N1)	Enterprise PAO (7M2) AQD
-----	---------------------	-----------------------	--------------------------



# Public Affairs Officer

## *Community Values*

- **Sustained superior performance, leadership and expertise in demanding billets and assignments**
- **Evidence of a learning mindset, innovative problem solving and data-driven decision making**
- **Valued Reserve contributions to Navy mission via operational / mobilization assignments and Canvasser Recruiter duty during FY23 and beyond**
- **Valued achievements at ALL PAYGRADES**
  - NOBC 2412, NRAU CO/OIC AQD (2N1), NRUM, Advanced Degree / Certification, Joint Experience / Education
- **Valued achievements prior to LIEUTENANT COMMANDER**
  - Demonstrated operational-PA expertise in planning and execution, particularly Fleet/Joint exercises and contingency/crisis response
  - Department Head (DH) or Assistant DH responsibilities
  - Demonstrated performance of PA tactics, particularly supporting Operational Level of War (OLW), Maritime Operations Center (MOC), and/or Operations in the Information Environment (OIE) concepts
- **Valued achievements prior to COMMANDER**
  - Sustained superior performance in Fleet/Joint exercises; experience conducting PA during Fleet/Type Command maritime operations
  - Contingency operations/crisis response experience in an operational/strategic planning PAO billet
  - Superior leadership in an XO, AOIC or senior DH role
  - Documented experience as a PA advisor to Unrestricted Line (URL) operators
  - Demonstrated success of senior-level PA skills: strategic planning, staff coordination/synchronization, sr. leader messaging/media prep, PA spokesperson; and OLW, MOC, and OIE PA capabilities
- **Valued achievements prior to CAPTAIN**
  - Sustained superior performance in unit leadership and management in an O5 milestone-eligible billet, community priority billet, or other CO/OIC/XO billet
  - Documented superior performance over 18 months in a community priority billet providing strategic-level counsel to flag or general officers or the Enterprise PAO AQD (7M2)
  - Contingency operations/crisis response experience in an operational/strategic advisor PAO billet
  - Demonstrated ability to design & execute communication strategies that promote commander's intent and command goals
  - Documented superior performance as senior-level PA advisor in fleet exercises and/or operations; communication synchronization with staffs/subordinate higher-headquarters; and OIE, OLW, and/or MOC PA capabilities
  - Demonstrated success of leadership contributions to community management initiatives/collateral duty assignments



# Special Warfare (SEAL) Officer Career Progression

## Career Path

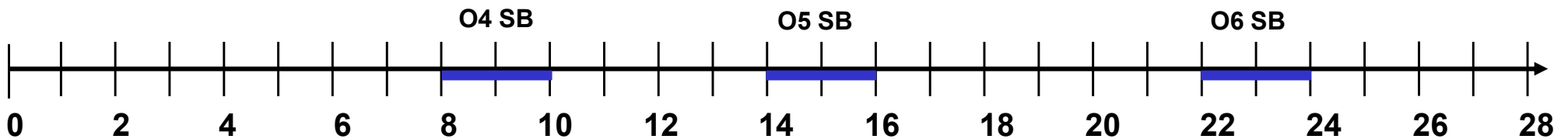
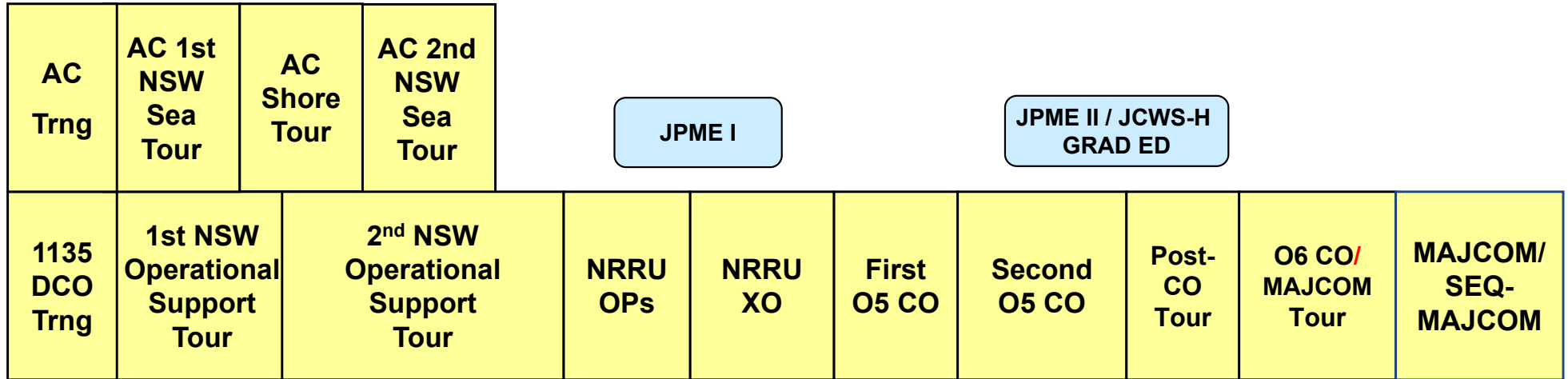

## Typical Billets

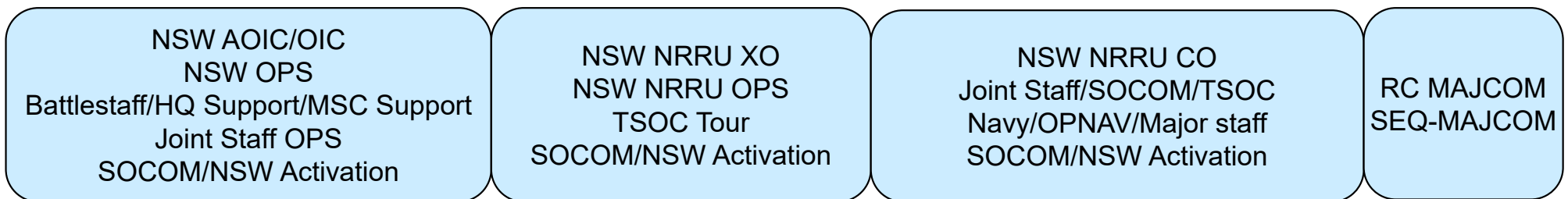



# Special Warfare (SEAL) Officer

## *Community Values*

- **Sustained superior performance, leadership and expertise in demanding billets and assignments**
- **Evidence of a learning mindset, innovative problem solving and data-driven decision making**
- **Valued Reserve contributions to Navy mission via operational / mobilization assignments and Canvasser Recruiter duty during FY23 and beyond**
- **Valued achievements at all paygrades**
  - Demonstrated leadership through initiative, responsiveness, and proactive actions
  - Graduate education in any field regardless of source or method of achievement
  - Joint experience and Joint Professional Military Education is valued at any rank
- **Valued achievements prior to LIEUTENANT COMMANDER**
  - Served/Serving Department Head (RC Troop Commander, Operations Officer)
  - Recognized top performer in community prioritized positions (SDV, SBT, SEAL, SRT)
  - Successful completion of assigned AC NSW Platoon Cdr tour (SDV, SBT, SEAL, SRT)
  - Successful deployment (>6 mos) in support of SOF requirement
- **Valued achievements prior to COMMANDER**
  - Served/Serving NSW NRRU XO minimum 12 months
  - 2N1 AQD complete
  - NR TSOC tour
  - Recognized top performer in community prioritized positions (SOCOM/NSWC prioritized JIAs – JCS named operations/overseas deployment, SDV, SBT, SEAL, SRT, TSOC)
  - Successful deployment (> 6 mos) in support of SOF requirement
- **Valued achievements prior to CAPTAIN**
  - Multiple O5 NSW RC leadership positions (NRRU CO, XO, COS)
  - NSW NRRU Command tour complete
  - Recognized top performer in community prioritized positions (SOCOM/NSWC prioritized JIAs, SDV, SBT, SEAL, SRT, JSOC)
  - Successful deployment (> 6 mos) in support of SOF requirement



# Special Warfare (SEAL) Officer (TAR)

## Career Progression

### Career Path

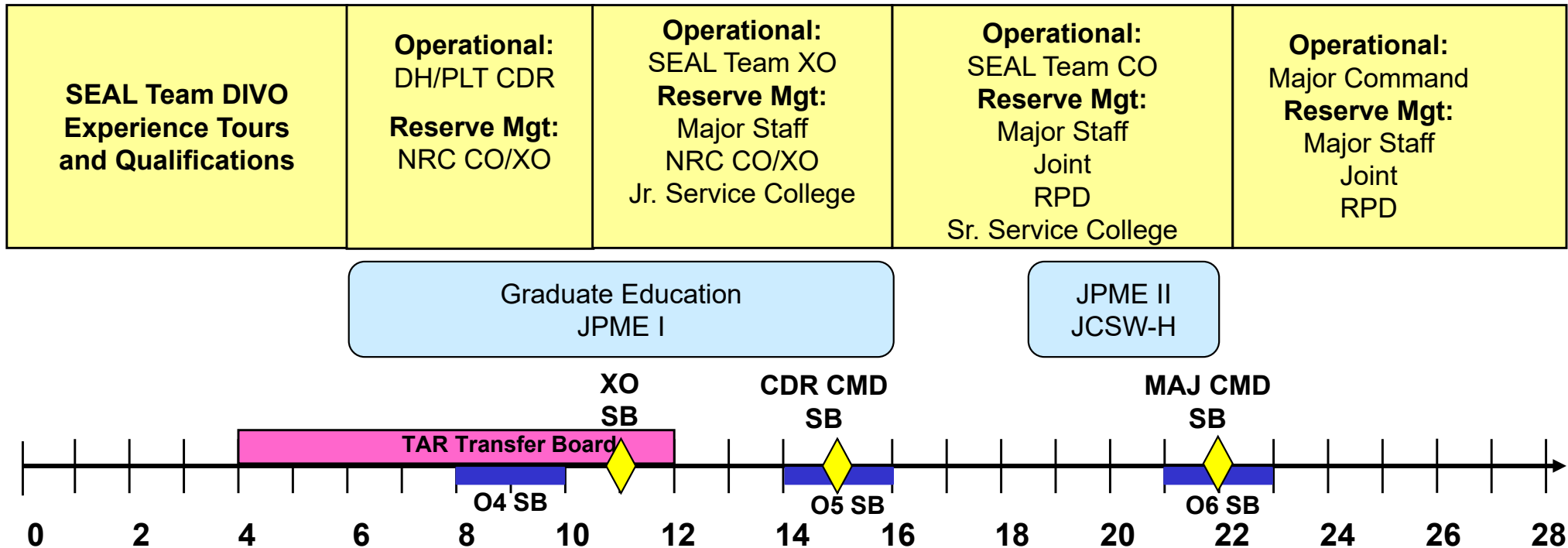

**RESERVE MANAGEMENT:**  
 NRC CO – 24-36 Month Tours  
 Major Staff (OCNR/CNRFRC/REDCOM/RPD/NSWC/NSWG-11)



# Special Warfare (SEAL) Officer (TAR)

## *Community Values*

- **Sustained superior performance, leadership and expertise in demanding billets and assignments**
- **Evidence of a learning mindset, innovative problem solving and data-driven decision making**
- **Valued achievements prior to LIEUTENANT COMMANDER**
  - Served/Serving Department Head
  - Recognized top performer in tactical/operational and screened community positions (JSOC, NSWDG/TACDEVIRON, SMU, TSOC, SDV, SBT, SEAL, SRT)
- **Valued achievements prior to COMMANDER**
  - Served/Serving NSW XO (Afloat or Ashore), Troop Commander, Operations Officer, or served/serving O-4 NRC CO
  - Recognized top performer in tactical/operational and screened community positions (JSOC, NSWDG/TACDEVIRON, SMU, TSOC, SDV, SBT, SEAL, SRT)
- **Valued achievements prior to CAPTAIN**
  - Served/Serving NSW CO (Afloat or Ashore) or served/serving O-5 NRC CO
  - Sustained superior performance in operational and Reserve management leadership positions
  - Recognized top performer in tactical/operational and screened community positions (JSOC, NSWDG/TACDEVIRON, SMU, TSOC, SDV, SBT, SEAL, SRT)
  - Requirements or financial management qualification and/or experience
- **Graduate education in any field is valued regardless of source or method of achievement**
- **Joint experience and Joint Professional Military Education is valued**



# Strategic Sealift Officer

## Career Progression

### Career Path

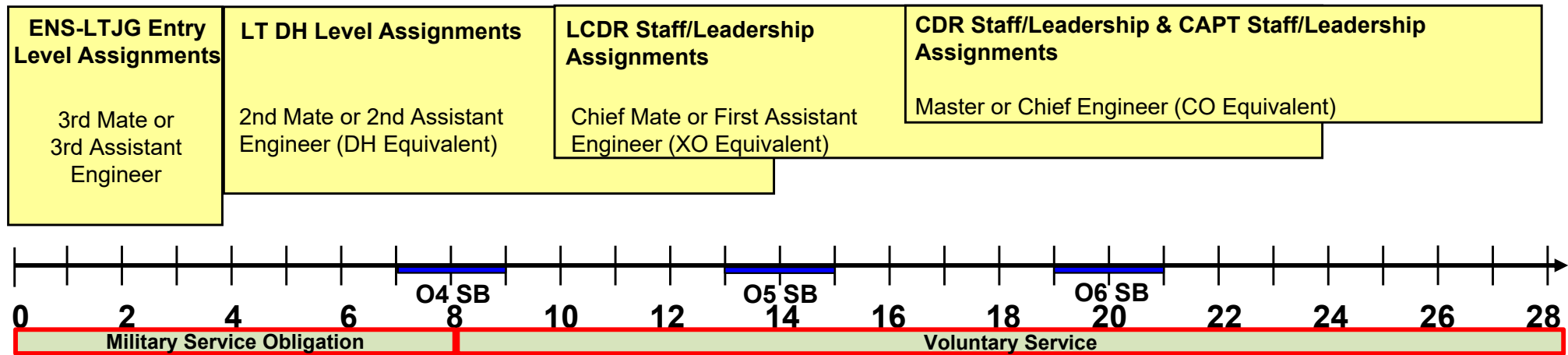

### Typical Billets

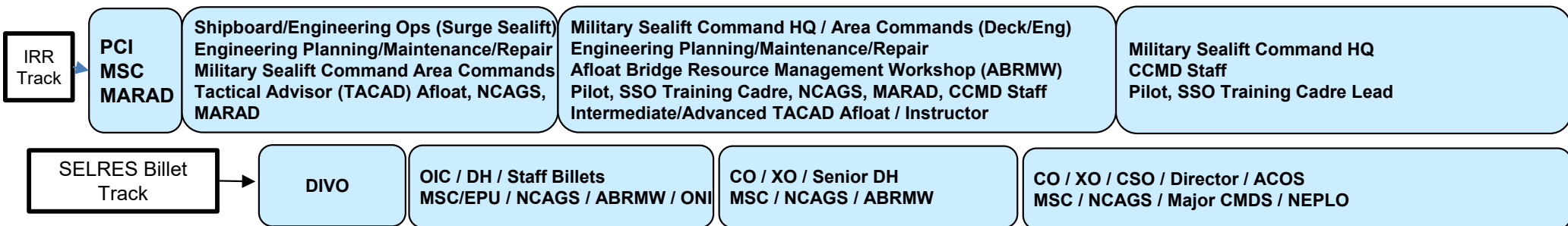

### Professional Milestones

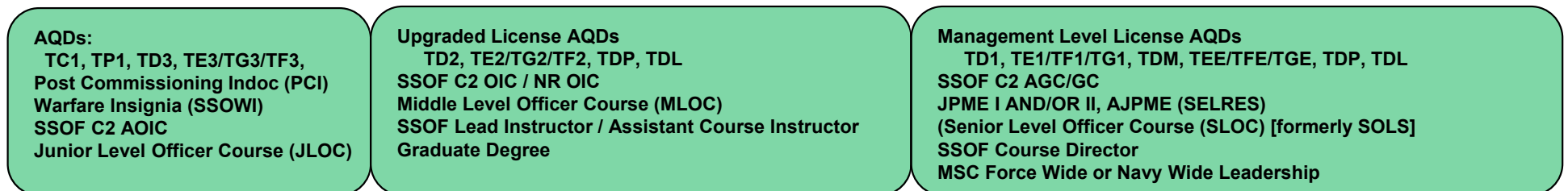



# Strategic Sealift Officer

## Community Values

- Sustained superior performance, leadership and expertise in demanding billets and assignments
- Evidence of a learning mindset, innovative problem solving and data-driven decision making
- Valued Reserve contributions to Navy mission via operational / mobilization assignments and Canvasser Recruiter duty during FY23 and beyond
- Strategic Sealift Officers are licensed as U.S. Merchant Mariners who are qualified to operate merchant ships as naval auxiliaries and provide officer crewing for ships activated from MARAD's Ready Reserve Force and operated by COMSC during competition, conflict, and crisis
- Approximately 90% of the SSO Program members are individual ready reservists (IRR) and are normally employed afloat as licensed Mariners in their civilian careers. The remainder are in the Selected Reserve (SELRES). Both career paths are viable options and are valued
- SELRES records are identifiable by a continuity of observed FITREPs and should be selected for promotion based upon sustained superior performance in demanding leadership assignments, similar to other communities. SELRES affiliation typically occurs at LT or above
- IRR are identifiable by a majority of Non Observed (NOB) FITREPs which discuss annual service requirement of 12 days of ADT. IRR who receive 'Observed' FITREPS or Personal Decorations should be viewed favorably. IRR should show consistent program participation through ADT and advanced USCG Merchant Marine-license
- Valued achievements at all paygrades
  - Required to maintain USCG Merchant Marine Unlimited License. The AQD must be in OSR or a copy of a valid license must be in the LTB, **No Exceptions!**
  - Proven leadership (Navy or Civilian At Sea). Significant civilian leadership should be considered
  - Advanced USCG Merchant Marine License (Master/1<sup>st</sup>/2<sup>nd</sup> Officer or Chief/1<sup>st</sup>/2<sup>nd</sup> Assistant Engineer)
  - Command assignments and successful leadership tours supporting MSC and Fleets or Joint Force
  - Navy courses, continuing education, JPME
  - Long Term ADT/ADOS supporting CNRFC N14, US Transportation Command, MSC, or Joint Commands
  - Proficiency at sea with meaningful underway experience within the last four years
  - Wide range of operational/engineering NOBCs and AQDs in record
  - Master's or Doctoral Degree (Management, Engineering, Admiralty Law, Logistics, and National Security)
  - Professional Engineer License and Professional Certifications (DAWIA, IT, PM)
- Valued achievements prior to LIEUTENANT COMMANDER
  - **IRR** Advanced USCG Merchant Marine License (2<sup>nd</sup> Officer or 2<sup>nd</sup> Assistant Engineer) or **SELRES** DH tour
  - Active Service aligned to Maritime Operations: MSC HQ, MOC, Logistics, Security, Mobilization/ADOS/long term ADT
  - Recent service (within last 4-5 years) underway as TACAD and/or Afloat Bridge Resource Management Works
  - SSOF Command and Control leadership (OIC/AOIC/TRAINO/ADMINO)
- Valued achievements prior to COMMANDER
  - **IRR** Management Level USCG Merchant Marine License (Chief Mate / Master or 1<sup>st</sup> Assistant Engineer / Chief Engineer) or **SELRES** Senior DH/XO/OIC tour
  - Active Service aligned to Maritime Operations, Training, Engineering, Maintenance or Operational Planning; significant Navy or civilian leadership
  - SSOF Command and Control leadership (Assistant Group Commander/OIC/AOIC/TRAINO/ADMINO)
- Valued achievements prior to CAPTAIN
  - **IRR** Management Level USCG Merchant Marine License (Master or Chief Engineer) or **SELRES** O5 CO Tour
  - Significant Community Leadership in the SSOF Command and Control Structure
  - Major Staff or Joint Experience



# Submarine Warfare Officer

## Career Progression

### Career Path

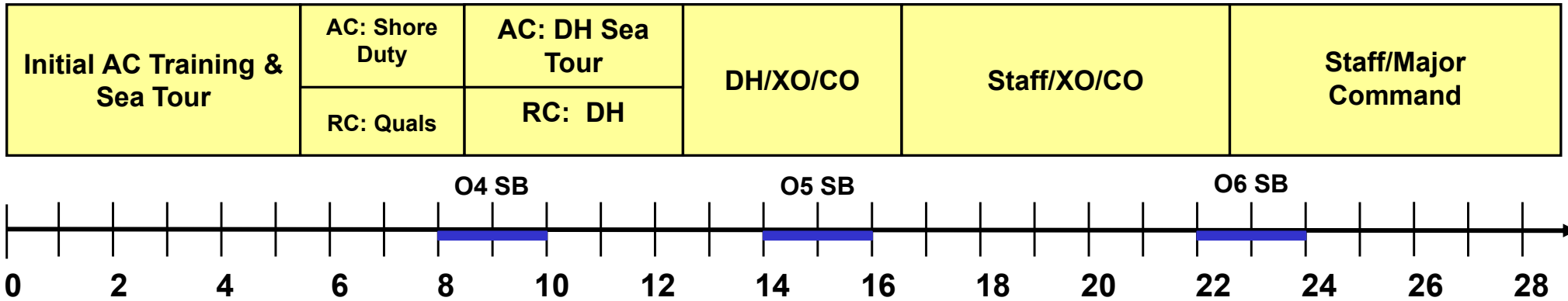

### Typical Billets

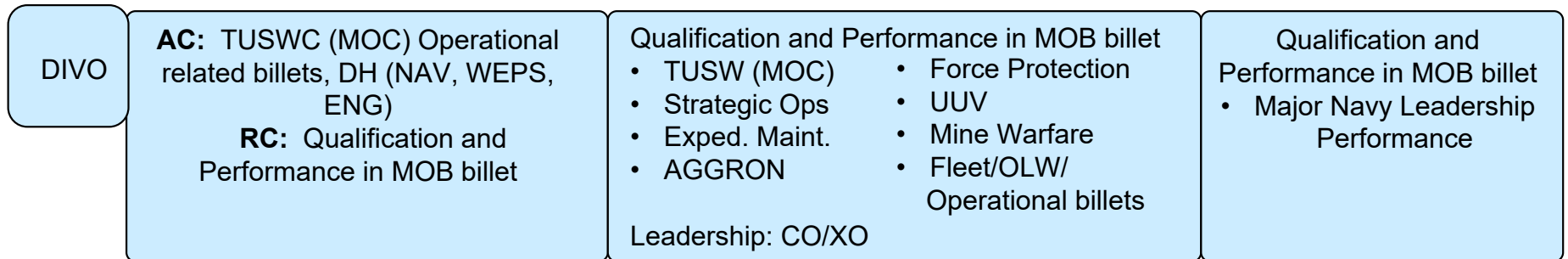

### Expected Qualifications/Valued Achievements





# Submarine Warfare Officer

## *Community Values*

- **Sustained superior performance, leadership and expertise in demanding billets and assignments**
- **Evidence of a learning mindset, innovative problem solving and data-driven decision making**
- **Valued Reserve contributions to Navy mission via operational / mobilization assignments and Canvasser Recruiter duty during FY23 and beyond**
- **Valued achievements at all paygrades**
  - TUSWC, real world events followed by Exercises
  - Varied experience, particularly in UUVRON or OLW assignment
  - STRAT OPS (Battle staff, Operations, Targeting)
- **Valued achievements prior to LIEUTENANT COMMANDER**
  - Successful active-duty tours
  - Successful leadership positions
- **Valued achievements prior to COMMANDER**
  - Successful CO / XO / DH leadership positions
  - Qualified TASWWO (BA6: TASW WATCH OF) or STRAT OPS ABWC
- **Valued achievements prior to CAPTAIN**
  - Successful CO / XO leadership positions
  - Qualified BWC (including BWC for TUSWC, STRAT OPS, Named or Numbered Fleets (e.g., C3F, CPF, USFFC, etc.), OPNAV, or other equivalent CTF)
- **Other valued achievements**
  - JPME
  - Advanced degree
  - Navy support of major initiatives or programs



# Submarine Warfare Officer (TAR)

## Career Progression

### Career Path

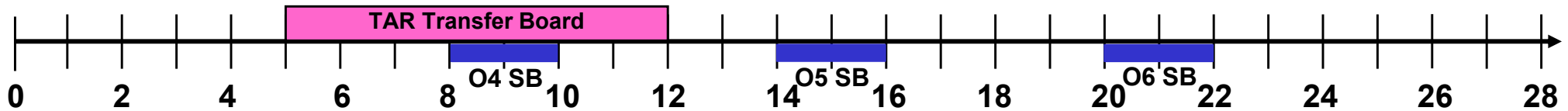
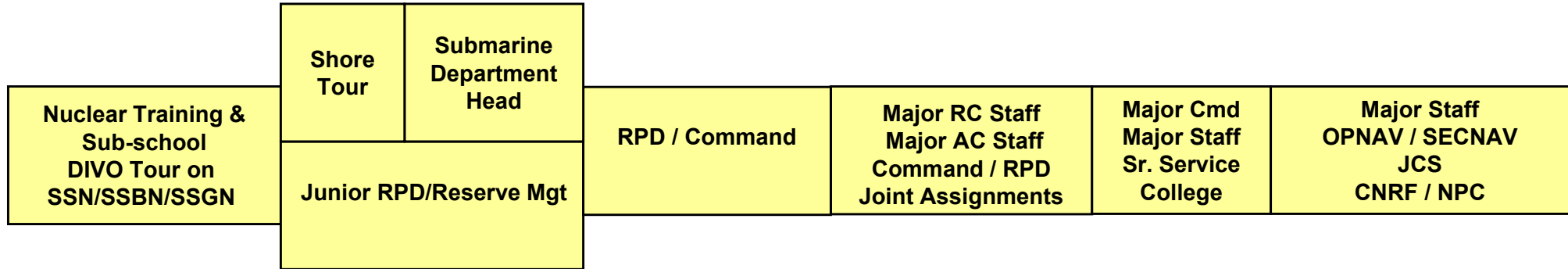

### Expected Qualifications/Valued Achievements

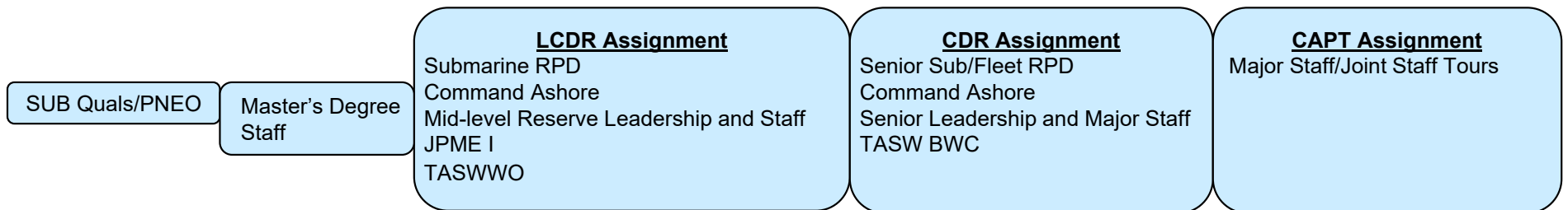

### RESERVE MANAGEMENT:

- Command – 24-36 Month Tours
- Major Staff (OCNR/CNRF/REDCOM/RPD)



# Submarine Warfare Officer (TAR)

## *Community Values*

- **Sustained superior performance, leadership and expertise in demanding billets and assignments**
- **Evidence of a learning mindset, innovative problem solving and data-driven decision making**
- **Valued achievements prior to LIEUTENANT COMMANDER**
  - Submarine service at sea – successful initial sea tours
  - Successful Reserve Management Experience (e.g., RPD, NRC XO)
- **Valued achievements prior to COMMANDER**
  - Successful Department Head at-sea or Command Ashore tour (e.g., NRC)
  - Successful Reserve Program Director at Submarine Force commands, Deputy RPD at large staff or in reserve management tour
  - Master's degree or JPME I complete
- **Valued achievements prior to CAPTAIN**
  - Successful Command Ashore tour (e.g., NRC, RTAG)
  - Successful Reserve Management/Leadership tour at Major Staff (e.g., OPNAV, PERS, OCNR, CNRFC, REDCOM CSO)
  - Reserve Program Director at Submarine Force commands or Major AC Staff (e.g., TYCOM, Numbered Fleet)
- **Reserve management tours**
  - Officers serving in Reserve management/leadership positions are directly supporting the mission of the TAR community (e.g., OCNR, CNRFC, REDCOM)
  - Successful command tour and outstanding performance on major staffs are key indicators of potential success at the next higher paygrade



# Surface Warfare Officer Career Progression

## Career Path

Initial AC Sea Tours	AC Shore Duty	AC DH Sea Tour	<u>Mid-grade Leader</u> Command, Specialty Qual Tour / Staff	<u>Senior Leader</u> MSRON CO/XO CDR Command Major Staff	<u>Strategic Leader</u>	
	RC Experience / Staff Tours				O6 Command MAJCOM	SEQ MAJCOM Post

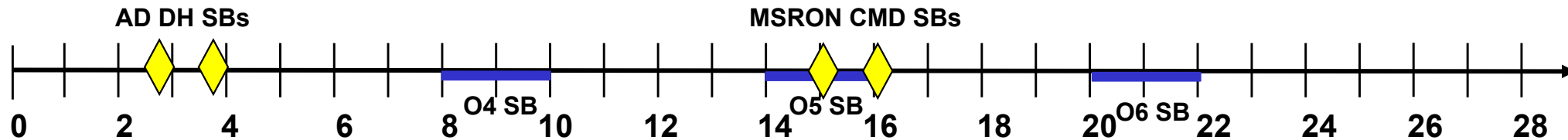

### Typical Billets

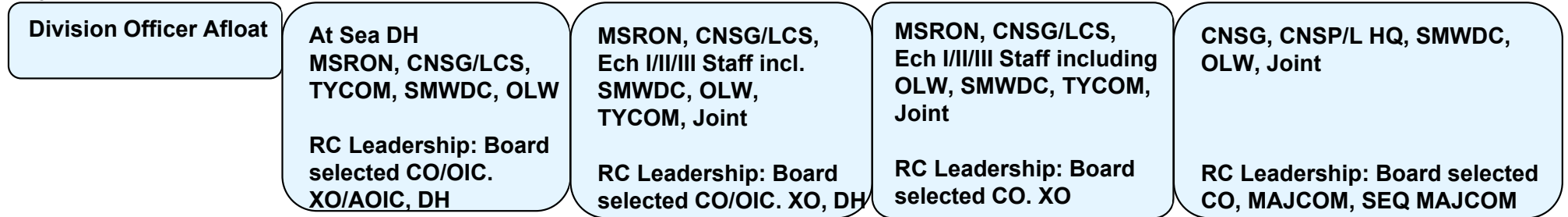

### Operational Expertise/ Professional Achievements

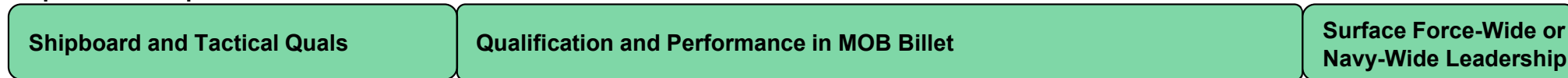



# Surface Warfare Officer

## *Community Values*

- **Sustained superior performance, leadership and expertise in demanding billets and assignments**
- **Evidence of a learning mindset, innovative problem solving and data-driven decision making**
- **Valued Reserve contributions to Navy mission via operational / mobilization assignments and Canvasser Recruiter duty during FY23 and beyond**
- **Valued achievements at all paygrades**
  - Proven leadership
    - MSRON Command at Sea, Reserve Unit Command/OIC, MAJCOM, SEQMAJCOM, post-command and milestone assignments, service at sea as a DH afloat or senior
    - Successful leadership positions in high-profile/demanding/high-OPTEMPO Surface Force Units (CNSG/LCS, OLW, MSC, MESF/MSRON, BEACHGRU, USVRON, SMWDC, CNSP/L TYCOM HQ)
  - Career variety / subject matter expertise
    - Experience/qualifications within specialty/high demand fields (Commander Naval Surface Forces, SMWDC, CNSG/LCS, MESF, Numbered Fleet Commands, Fleet MOCs, OPNAV, PACFLT/USFF, Joint)
    - Advanced degree and certifications demonstrating continual learning
- **Valued achievements prior to LIEUTENANT COMMANDER**
  - Successful DIVO tours at sea; successfully serving as DH Afloat is highly valued, Reserve Component affiliation and integration
  - Leadership and advancement recommendations
- **Valued achievements prior to COMMANDER**
  - Successful leadership tours with qualifications/NOBC/AQDs in Surface Pillar units: Naval Surface Force, MESF/MSRON, OLW, MSC
  - Increasing leadership, span of control, and complexity (force generation / force employment) in unit size and mission
- **Valued achievements prior to CAPTAIN**
  - Career progression within Surface Force units
  - Variety of experience within Surface Reserve Force, Numbered Fleet, and Combatant Commands
  - Surface Warfare Reserve Enterprise participation
- **Other valued achievements**
  - Experience: ROC, BWC, Operational Planning, Fires/Targeting, AEGIS/IAMD/BMD, UxS, Area Cmdr, Cyber/Space
  - Education & Quals: 2N1, 2N2, 2N3, 2N4, 2D1, 2D2 – Command at Sea, BWC, JPME, JQO, MSOC/ELOC/MHSC, NSLS, RCNSC, WTI



# Surface Warfare Officer (TAR)

## Career Progression

### Career Path

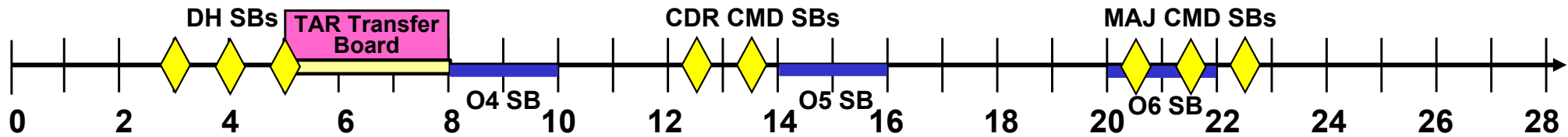
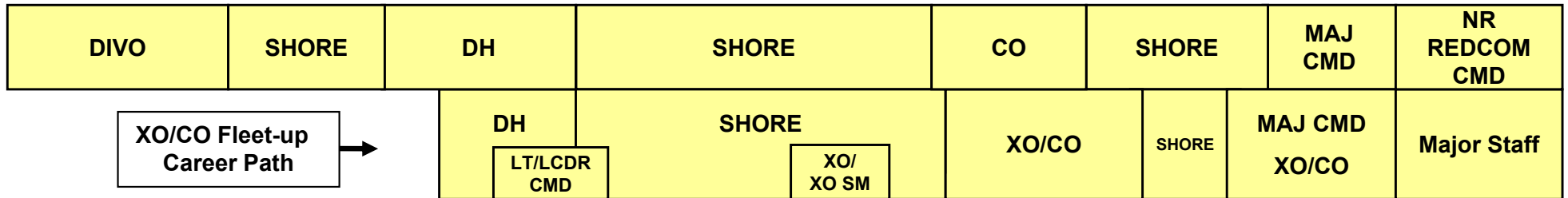

### Typical Billets/Valued Achievements

<ul style="list-style-type: none"> <li>Divo Afloat SWO Quals</li> </ul>	<ul style="list-style-type: none"> <li>Master's NRC Reserve Mgt</li> </ul>	<ul style="list-style-type: none"> <li>DH Afloat TAO/EOOW Qual</li> </ul>	<ul style="list-style-type: none"> <li>NRC XO/CO RPD: Ech IV/V</li> <li>Asst RPD Reserve Mgt</li> <li>JPME-I</li> <li>MSRON</li> <li>Small Craft Pin</li> </ul>	<ul style="list-style-type: none"> <li>CO Afloat / MSRON</li> <li>CO Special Mission</li> <li>RTAG/NTAG/NRC CO</li> <li>XO Afloat / XO Special Mission</li> <li>RPD: CNSG, CNSP/L, Ech I/II/III</li> <li>Major Staff/JPME-II</li> </ul>	<ul style="list-style-type: none"> <li>Major Command Afloat</li> <li>Major Command Ashore</li> <li>REDCOM / Large NRC CO</li> <li>Senior CNSP/L RPD</li> <li>Major Staff Reserve Mgt</li> </ul>
---	--	---	---	---	---

**RESERVE MANAGEMENT:**  
 NRC/RTAG/NTAG CO – 24-36 Month Tours  
 Major Staff (OCNR/CNRF/REDCOM)  
 RPD Priorities: CNSP/L, CNSG



# Surface Warfare Officer (TAR)

## Community Values

- **Sustained superior performance, leadership and expertise in demanding billets and assignments**
- **Evidence of a learning mindset, innovative problem solving and data-driven decision making**
- **Valued achievements prior to LIEUTENANT COMMANDER**
  - Service at sea – successful initial sea tours
  - Screened for, or successfully serving as, DH Afloat
- **Valued achievements prior to COMMANDER**
  - Service at sea – superior performance as DH Afloat
  - Recognized top performer at major community and Reserve management assignments (e.g., OPNAV, BUPERS, OCNR, CNRFC, NPC, SURFLANT, SURFPAC, etc.)
  - Screened for Afloat XO/CO fleet-up, Commander Command, XO or XO special mission
  - Successful completion of Reserve management tour (NRC/RTAG/NTAG CO, REDCOM, or CNRFC Staff)
  - Master's degree / JPME I awarded
- **Valued achievements prior to CAPTAIN**
  - Successful surface ship, MSRON, or other operational Commander Command tour (e.g. USVRON, ACU, BMU)
  - Successful special mission command tour
  - Successful Reserve management leadership tour (NRC/RTAG/NTAG CO)
  - Successful completion of major Reserve management staff tour (OCNR or CNRFC)
  - Requirements or financial management qualification
  - Operational and Reserve management leadership positions
  - Sub-specialty utilization
- **Reserve management tours**
  - Officers serving in Reserve management/leadership positions are directly supporting the mission of the TAR community (i.e. RPD, OCNR, CNRFC, REDCOM, etc.)
  - Successful NRC/RTAG/NTAG command and outstanding performance on major staffs are also key indicators of potential success at the next higher paygrade
  - Requirements or financial management positions(i.e. OCNR N0959, OPNAV N80, N81, N82, N96, N95, N4)



# Limited Duty Officer (Line)

## Career Progression

### Typical Billets

Surface	DIVO	XO/DH	CO/XO/OIC	CO/Major Command XO/Major Staff	Major Staff
Submarine	DIVO/DH	XO/CO	Submarine Exp. Maint Unit CO	Sub Force Augment Unit CO/MAJCOM-Staff NOBC 7976 Ship Repair Officer	Sub Force Mission Area Lead MAJCOM Staff
Aviation	DIVO	QAO/MCO/MMCO	MCO/MMCO/AMO	Squadron Maintenance Officer (MO)/Major Staff	Major Staff
Admin	DIVO	DH/ Joint Staff	OIC/XO/DH/NLEC Instructor/Joint Staff	Major Staff/Joint Staff	Major Staff
Security	NSF CO/XO/OIC/DIVO/ 2N1/NSFO/	CO/XO/OIC/DIVO/CNIC/MES F/FPO/ MSC/NCIS SUBGRU 9/10 FP XO	CO/OIC/CNIC MSC/MESF FPO/RSC SUBGRU 9/10 FP XO	Major Staff Security Officer CNIC Region Reserve Security CO	CNIC Deputy Director Force Protection /NAVSEA 10G2 Deputy Director Security /CNIC Region Reserve Security CO
IWC	DIVO/ADH/IP OPS/ANALYST	DH/REGSTF/TEAM LD/SEN ANALYST/ STRIKE LD	IWC LDOs are transitioning via Off-Ramp to RL counterpart resulting in no funded control grade requirements for this FY		

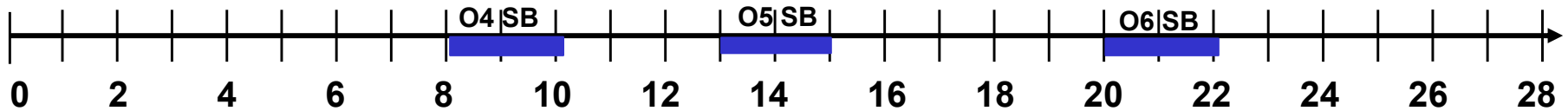

<p>LDO/CWO Academy in year 1</p> <p>Warfare Quals if available</p> <p>Designator NOBC/AQD's</p>	<p>Increase in scope</p> <p>Added technical/tactical skills</p> <p>Broaden experience outside designator</p>	<p>Continued growth; technical and education</p> <p>CO/XO experience</p> <p>Maintains specialty relevance</p>	<p>CMD and/or senior staff assignments</p> <p>Leadership, management, and command (LMC) skills</p> <p>Life-long learning NO LONGER "LIMITED"</p>	<p>Sought after Leader Flag/Fleet engagement</p> <p>Mentor's senior officers, Active LDO/CWO community leader and highly visible within Enterprise</p> <p>Life-long learning, 30+ years of service</p>
---	--	---	--	--



# Limited Duty Officer (Line)

## *Community Values*

- **Sustained superior performance, leadership and expertise in demanding billets and assignments**
- **Evidence of a learning mindset, innovative problem solving and data-driven decision making**
- **Valued Reserve contributions to Navy mission via operational / mobilization assignments and Canvasser Recruiter duty during FY23 and beyond**
- **Valued achievements at all paygrades**
  - Upward progression in scope of management and leadership throughout career; documented mentorship
  - Demonstration of increased technical expertise within community followed by variety of experience both operational and professional
  - Continues higher education and/or life-long professional learning (e.g., certificates, degrees, MSOC, ELOC, NRAU Command AQD 2N1/2N2, instructor duty, planner, Leadership/Ethics, Project Management, NWC courses, and JPME)
  - Engaged, recognized, documented RC LDO/CWO Community support
- **Valued achievements prior to LIEUTENANT COMMANDER**
  - Sustained superior performance in CO/XO/DH/OIC/Squadron MMCO/QAO assignments
- **Valued achievements prior to COMMANDER**
  - Sustained superior performance in CO/XO/OIC/DH/Squadron AMO and Deputy Region Security Commanding Officer assignments
- **Valued achievements prior to CAPTAIN**
  - Sustained superior performance in CO/XO/Milestone tours/Maj Command DH/Squadron Maintenance Officer (MO)/ and CNIC Region Security Commanding Officer assignments
- **LDO/CWO Community participation, involvement and representation**
  - Documented mentorship of junior personnel based on the demographics of particular job (officers and enlisted)
  - Familiar with all LDO/CWO designator career paths and actively seeks out candidates for the program
  - A visible and positive representative of the community to the Fleet
  - Engagement and Impact within the Community