

Chief Petty Officer Uniform Requirements and Allowances

Attention Chiefs and future Chiefs! Did you know that the special initial clothing allowance (SICA) only pays for items that are mandatory requirements for newly advanced Chiefs? Table 1 lists all required mandatory uniforms each Chief is expected to have in their sea bag immediately upon pinning. Having the required CPO uniforms is relative to knowing what needs to be in your sea bag, understanding your allowances, and knowing what is mandatory versus what is optional.

Your first allowance, SICA, is paid to active, TAR and selected reserve Chiefs upon the date of advancement vice date of frocking (Ref: DoD Financial Management Regulation Vol. 7A, Chapter 29). The SICA covers the cost of the items and respective quantities listed in Table 1. For FY 2024, the SICA rate is \$1,243.92 for male CPOs and \$1,214.88 for female CPOs. SICA is updated every year on 1 October to align with the new fiscal year's clothing requirements and updated costs.

All CPOs are expected to maintain various uniforms items also worn by junior enlisted personnel E1 - E6. Table 2 lists those E6 items required of a CPO that are supported by an annual clothing allowance (see description provided below). Item quantities to be maintained are relative to mission needs, but there is no mandatory minimum required.



CPO Selectee Uniform Fitting. Photo by: James Foehl (Source: www.dvidshub.net)

Table 1: Mandatory CPO Items (FY24)		Male		Female		Table 2: E6 Items Required of a CPO (FY24)		Male		Female	
Item	#	Cost \$	#	Cost \$	Item	#	Cost \$	#	Cost \$		
Belt, Black, (No Buckle)	1	11.71			Blousing Straps	2	4.32	2	4.32		
Belt, Khaki, (No Buckle)	1	11.71	1	10.05	Boots, 9"	1	152.63	1	152.06		
Belt, White, (No Buckle)	1	9.22	1	8.30	Cap, Utility w/ACE Logo	2	26.84	2	26.84		
Buckle	2	19.04	2	19.04	Drawers, Cotton, White	8					
Cap Covers: Khaki, Poly/Wool	1	22.69	1	21.55	Gloves, Black Leather	1	27.51	1	27.51		
Unisex Combination Hat w/White Cover	1	66.97	1	63.73	Jacket, Fitness Suit	1	61.40	1	61.40		
Cap Device, CPO	1	13.50	1	13.50	Liner, Fleece	1	79.15	1	79.15		
Gloves, White	1	6.71	1	6.71	Mock Turtle Neck	1	34.50	1	34.50		
Insignia:					Pants, Fitness Suit	1	51.02	1	51.02		
Collar Devices; set	1	18.00	1	18.00	Parka, Cold Weather, Bl	1	155.70	1	155.70		
Rating Badge, Black	1	23.78	1	23.78	Parka, NWU Type III	1	209.51	1	209.51		
Shoulder Boards, Soft; set	1	9.25	1	9.25	Shirt, Khaki, Poly/Wool	2	89.42				
Necktie/Neck Tab, Black	1	8.21	1	12.96	Overblouse, Khaki			2	71.32		
Shirt, White, CNT	1	42.78	1	42.78	Shirt, NWU Type III	3	135.96	3	135.96		
Shirt, White, Poly/Cotton, Lg Slv	1	45.15	1	45.15	Socks, 9" Boot	5	9.00	5	9.00		
Shoes, White	1	1115.00	1	115.00	Socks, Cotton/Nylon, Bl	3	2.70	3	2.70		
Socks, White	1	5.39	1	5.39	Trousers, NWU Type III	3	171.93	3	171.39		
Trousers/Slacks:					Undershirt, Cotton, Br	4	16.88	4	16.88		
Khaki, Poly/Wool	1	97.39	1	97.39	Undershirt, Cotton, Wh	4	18.88	4	18.88		
White, CNT	1	67.65	1	67.65	Shoes, Black, Dress	1	66.25	1	64.19		
Service Dress Blue-Coat/Trsr/Slck	1	439.00	1	412.00	Shirt, PTU	2	19.64	2	19.64		
Service Dress White-Coat	1	224.00	1	224.00	Shorts, PTU	2	31.42	2	31.42		
SDW Collar Devices; set	1	23.23*	1	23.23*							

Common Items Not Supported by Clothing Allowances (Not all-inclusive)

- Commercial Khaki Shirt (men)
- Dress White Slacks (women)
- Brooks Brothers SDB
- Brooks Brothers Dress White Shirt and Neck Tie
- Dinner Dress Jacket Uniforms
- Jacket, Black (Eisenhower)
- Optional PTU (Shirt/Shorts)
- V-Neck Sweater
- Riggers Belt
- CPO Cutlass & Components
- All Skirts
- Optional Dress Shoes (brown) / Optional Work Boots (brown)
- Female Pumps & Flats
- Medals, Warfare Devices
- Pea Coat/Reefar
- All-Weather Coat
- NWU Shoulder Patches
- Commercial T-shirts (white or brown)

* Prices listed are effective 1 October 2023 through 30 September 2024. Uniform prices are set every Oct 1st. When absolutely necessary, prices may be adjusted during the FY.

Standard Cash Clothing Replacement Allowance(Standard CCRA):	Paid annually during the first 3 years following receipt of SICA and at the end of the advancement anniversary month. The Standard CCRA supports the replacement of E6 clothing items based on their individual wear life.
Special Cash Clothing Replacement Allowance(Special CCRA):	Paid annually to CPOs after completion of 3 years time-in-rate at the end of the advancement anniversary month. The Special CCRA supports the replacement of CPO uniforms and E6 uniform items required of a CPO based on their individual wear life.
Reserve Chief Petty Officers will receive 18 percent of the Active Duty CPO Special Cash Clothing Replacement Allowance. This allowance is paid annually during the anniversary month of the qualifying member.	

Navy Chief! Navy Pride!



Want to Know More?

A complete list of uniform item prices, useful life, and annual replacement allowance values can be found in the Navy Uniform Regulations, at: <https://www.mynavyhr.navy.mil/References/US-Navy-Uniforms/Uniform-Regulations/Chapter-3/General-Requirements/#3101.1>



CPO Clothing Allowances

Special Initial Clothing Allowance (SICA)	Paid upon advancement or first enlistment as a Chief Petty Officer in the Navy while serving on active duty, unless a special initial clothing allowance was previously paid. Chief Petty Officers on the Naval Reserve assigned to Selected Reserve and Voluntary Training units are entitled to a full special initial clothing allowance upon first advancement to Chief Petty officer.
Standard Cash Clothing Replacement Allowance (Standard CCRA):	Paid annually at the end of the advancement anniversary month during the first 3 years following receipt of SICA. Replacement allowances are intended to replace uniform items based on projected wear life.
Special Cash Clothing Replacement Allowance (Special CCRA):	Paid annually at the end of the advancement anniversary month after completion of 3 years, time in rate as a CPO. Provides for replacement of uniform items, after completion of 3 years of service, subsequent to receipt of a SICA.
Reserve Chief Petty Officers will receive 18 percent of the Active Duty CPO CCRA. This allowance is paid annually during the anniversary month of the qualifying member.	

Your Attention Please! Due to a supply chain issue, the standard choker collar devices will not be available for purchase and wear by CPOs who have yet to buy them. Instead, the standard CPO collar device is authorized for wear with a smaller yet much stronger backing clasp. To facilitate wear on the choker collar, center the standard collar device 1 ½ inch from the edge of the collar to the center of the anchor. Clear the Velcro patch and fasten. Ensure the backings are firmly in place before attempting to don and fasten the choker buttons and collar. Adjust each collar device to ensure equal spacing from the edge of the collar. This policy will be in place until we have obtained another source and sufficient inventory of the traditional CPO choker rank devices.

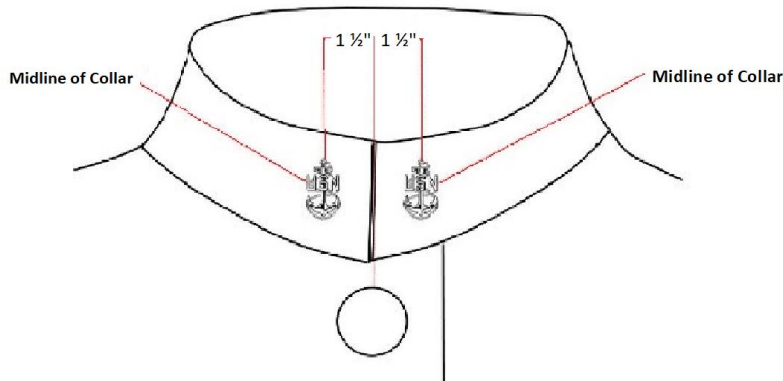

Things to Remember!

Bottom line up front, know what you need and get it early! The closer/better the off-the-rack uniform fit, the less alterations required and the less money you'll have to spend. If you can't find your size, ask the uniform store attendant. Don't wait until the last minute to determine your correct size is not available and you're stuck with having to accept whatever fits you (you will pay).

Know the difference between mandatory (CPO sea bag requirements) and optional items (nice to have). Your allowances cover mandatory items only.

Male khaki Poly/wool shirts: Worn by E1 through O10 are the same fabric, design and quality specifications! The difference in price of the two shirts is due to different distributors/manufacturers.

CNT khaki shirt, slacks, and skirts are authorized for wear: Shirts, slacks and skirts worn must be of the same fabric. Female Officer/CPO Summer White Slacks and Skirts are authorized for wear with the Service Dress White Coat.

New CPOs: Choose a payment or payment plan that aligns with your ability to procure your required uniforms prior to wearing the HAT. 0% interest option for 12 months is recommended for those who desire to defer full payment until receipt of SICA. Coincidentally, the deferred payment limit is \$1500, which aligns with your SICA payment. For those who are able to purchase their uniform requirements up front and fully out-of-pocket, there are money savings options for you to consider as well.

Last, but not least: Whenever in doubt about your CPO uniforms, ASK the uniform center store associate for information and assistance regarding component availability, sizing, fit, alternatives, etc. For policy guidance, manner, and occasion for wear inquiries, please contact umo_cmc@navy.mil.

